



INDICE

INDEX

INHALTSVERZEICHNIS

Dati tecnici REP

REP Technical data

Technische Daten REP

2

Dati tecnici EP

EP Technical data

Technische Daten EP

3

Simbologia

Measurement units

Maßeinheiten

4

1.0

**RIDUTTORI EPICICLOIDALI
SERIE REP**

**PLANETARY GEARBOXES
REP SERIES**

**PLANETENGETRIEBE
SERIE REP**

5

2.0

**RIDUTTORI EPICICLOIDALI
SERIE EP**

**PLANETARY GEARBOXES
EP SERIES**

**PLANETENGETRIEBE
SERIE EP**

27

3.0

APPENDICE

APPENDIX

ANHANG

47

REP 075																					Stadi Steps Stufenzahl				
Stadi Steps Stufenzahl	1				2								3								1	2	3		
i	3	4	5	6	9	12	16	20	24	30	36	27	36	48	64	80	100	120	144	180	216				
T_{2N}	35	45	35	30	40	50	50	50	50	40	35	40	55	55	55	55	55	55	55	40	35	n_{1nom}	4000	4500	5000
T_{2A}	55	65	55	50	60	70	70	70	70	60	55	60	80	80	80	80	80	80	80	60	55	n_{1max}	6000		
T_{2S}	110	130	110	100	120	140	140	140	140	120	110	120	150	150	150	150	150	150	150	120	110	LpA	< 70		
J_{min}	0.16	0.14	0.12	0.11	0.16	0.16	0.14	0.12	0.11	0.11	0.11	0.16	0.16	0.16	0.14	0.12	0.11	0.11	0.11	0.11	0.11	Lh	20000		
J_{max}	0.25	0.22	0.20	0.19	0.25	0.25	0.22	0.20	0.19	0.19	0.19	0.25	0.25	0.25	0.22	0.20	0.20	0.19	0.19	0.19	0.19	F_{R2}	1400		
Rt	4																				F_{A2}	700			
Td	0.96				0.93								0.91								α_{max}	4'	6'	8'	

Pag. Page Seite
16

REP 100																					Stadi Steps Stufenzahl				
Stadi Steps Stufenzahl	1				2								3								1	2	3		
i	3	4	5	6	9	12	16	20	24	30	36	27	36	48	64	80	100	120	144	180	216				
T_{2N}	90	110	90	75	100	115	115	115	115	85	75	100	120	120	120	120	120	120	120	95	80	n_{1nom}	4000	4500	5000
T_{2A}	145	170	130	120	160	180	180	180	180	140	130	160	190	190	190	190	190	190	190	150	130	n_{1max}	6000		
T_{2S}	290	340	260	240	320	360	360	360	360	280	260	320	380	380	380	380	380	380	380	300	260	LpA	< 70		
J_{min}	0.47	0.35	0.28	0.26	0.48	0.47	0.34	0.28	0.26	0.25	0.25	0.48	0.48	0.47	0.34	0.28	0.28	0.25	0.25	0.25	0.25	Lh	20000		
J_{max}	0.80	0.69	0.62	0.60	0.82	0.81	0.68	0.62	0.59	0.59	0.59	0.82	0.82	0.81	0.68	0.62	0.61	0.59	0.59	0.59	0.59	F_{R2}	2100		
Rt	11																				F_{A2}	1050			
Td	0.96				0.93								0.91								α_{max}	4'	6'	8'	

Pag. Page Seite
18

REP 125																					Stadi Steps Stufenzahl			
Stadi Steps Stufenzahl	1				2								3								1	2	3	
i	3	4	5	7	9	12	16	20	28	35	49	36	48	64	80	100	140	196	245	343				
T_{2N}	220	230	200	160	250	260	260	260	260	230	180	280	280	280	280	280	280	280	250	200	n_{1nom}	3000	3500	4000
T_{2A}	350	370	320	300	400	420	420	420	420	370	350	450	450	450	450	450	450	450	400	370	n_{1max}	5000		
T_{2S}	700	750	650	600	800	850	850	850	850	750	700	900	900	900	900	900	900	900	800	750	LpA	< 70		
J_{min}	1.91	1.18	0.84	0.64	1.93	1.85	1.14	0.82	0.62	0.63	0.62	1.92	1.84	1.14	0.81	0.80	0.62	0.61	0.61	0.61	Lh	20000		
J_{max}	5.10	4.36	4.02	3.82	5.11	5.03	4.33	4.00	3.81	3.81	3.81	5.11	5.03	4.32	4.00	3.98	3.80	3.80	3.79	3.79	F_{R2}	3700		
Rt	32																				F_{A2}	1850		
Td	0.96				0.93								0.91								α_{max}	4'	6'	8'

Pag. Page Seite
20

REP 150																					Stadi Steps Stufenzahl			
Stadi Steps Stufenzahl	1				2								3								1	2	3	
i	3	4	5	7	9	12	16	20	28	35	49	36	48	64	80	100	140	196	245	343				
T_{2N}	430	470	410	340	500	560	560	560	560	470	370	600	600	600	600	600	600	600	500	450	n_{1nom}	3000	3500	4000
T_{2A}	700	750	650	600	800	900	900	900	900	750	700	950	950	950	950	950	950	950	800	750	n_{1max}	5000		
T_{2S}	1400	1500	1300	1200	1600	1800	1800	1800	1800	1500	1400	1900	1900	1900	1900	1900	1900	1900	1600	1500	LpA	< 70		
J_{min}	6.58	4.64	3.64	3.05	6.54	6.32	4.49	3.55	3.01	2.99	2.97	6.51	6.31	4.49	3.55	3.61	2.98	2.97	2.97	2.97	Lh	20000		
J_{max}	12.94	11.00	10.01	9.42	12.90	12.69	10.86	9.92	9.37	9.35	9.34	12.87	12.67	10.85	9.91	9.87	9.35	9.34	9.34	9.34	F_{R2}	6600		
Rt	60																				F_{A2}	3300		
Td	0.96				0.93								0.91								α_{max}	4'	6'	8'

Pag. Page Seite
22

Dati tecnici EP

EP Technical data

Technische Daten EP

EP 55																		Stadi Steps Stufenzahl			
Stadi Steps Stufenzahl	1					2															
i	3	4	5	7	10	9	12	15	16	20	25	28	35	40	50	70	100	1	2		
T _{2N}	12	14	16	12	10	14	16	16	16	16	16	16	16	16	16	14	12	n _{1nom}	4000		
T _{2A}	22	24	24	22	20	24	28	28	28	28	28	28	28	28	28	24	22	n _{1max}	5000		
T _{2S}	44	48	48	44	40	48	56	56	56	56	56	56	56	56	56	48	44	LpA	< 70		
J _{min}	0.07	0.06	0.06	0.06	0.05	0.07	0.07	0.07	0.06	0.06	0.06	0.06	0.06	0.05	0.05	0.05	0.05	Lh	20000		
J _{max}	0.09	0.08	0.08	0.07	0.07	0.09	0.09	0.09	0.08	0.08	0.08	0.07	0.07	0.07	0.07	0.07	0.07	F _{R2}	300		
Rt	1.0					0.9												0.9		F _{A2}	450
Td	0.96					0.93												α _{max}		8'	10'

Pag. Page Seite

34

EP 75																		Stadi Steps Stufenzahl			
Stadi Steps Stufenzahl	1					2															
i	3	4	5	7	10	9	12	15	16	20	25	28	35	40	50	70	100	1	2		
T _{2N}	22	28	32	28	20	26	32	36	36	36	36	36	36	36	36	30	22	n _{1nom}	4000		
T _{2A}	40	45	50	45	40	50	60	60	60	60	60	60	60	60	60	50	45	n _{1max}	5000		
T _{2S}	80	90	100	90	80	100	120	120	120	120	120	120	120	120	120	100	90	LpA	< 70		
J _{min}	0.17	0.12	0.11	0.09	0.09	0.16	0.16	0.15	0.12	0.12	0.10	0.09	0.09	0.09	0.09	0.09	0.09	Lh	20000		
J _{max}	0.22	0.16	0.15	0.14	0.13	0.21	0.20	0.20	0.16	0.16	0.15	0.14	0.14	0.13	0.13	0.13	0.13	F _{R2}	1800		
Rt	3.5					3.0												3		F _{A2}	1400
Td	0.96					0.93												α _{max}		8'	10'

Pag. Page Seite

36

EP 90																		Stadi Steps Stufenzahl			
Stadi Steps Stufenzahl	1					2															
i	3	4	5	7	10	9	12	15	16	20	25	28	35	40	50	70	100	1	2		
T _{2N}	50	55	60	55	50	65	70	75	75	75	75	75	75	75	75	65	55	n _{1nom}	4000		
T _{2A}	80	90	100	90	80	100	110	120	120	120	120	120	120	120	120	100	90	n _{1max}	5000		
T _{2S}	160	180	200	180	160	200	220	240	240	240	240	240	240	240	240	200	180	LpA	< 70		
J _{min}	0.53	0.35	0.29	0.24	0.21	0.53	0.51	0.51	0.34	0.34	0.28	0.23	0.23	0.21	0.21	0.21	0.21	Lh	20000		
J _{max}	0.73	0.55	0.49	0.44	0.41	0.73	0.71	0.70	0.54	0.53	0.48	0.43	0.43	0.41	0.41	0.41	0.41	F _{R2}	2600		
Rt	9.0					7.5												9.0		F _{A2}	2000
Td	0.96					0.93												α _{max}		8'	10'

Pag. Page Seite

38

EP 120																		Stadi Steps Stufenzahl			
Stadi Steps Stufenzahl	1					2															
i	3	4	5	7	10	9	12	15	16	20	25	28	35	40	50	70	100	1	2		
T _{2N}	120	150	180	150	100	150	180	220	220	220	220	220	220	220	220	170	110	n _{1nom}	3000		
T _{2A}	190	240	290	220	180	240	290	350	350	350	350	350	350	350	350	270	200	n _{1max}	4000		
T _{2S}	400	500	600	460	380	500	600	700	700	700	700	700	700	700	700	540	400	LpA	< 70		
J _{min}	2.02	1.13	0.86	0.62	0.50	2.00	1.92	1.88	1.07	1.05	0.80	0.60	0.60	0.50	0.49	0.49	0.49	Lh	20000		
J _{max}	4.17	3.28	3.01	2.77	2.65	4.15	4.07	4.03	3.22	3.20	2.95	2.75	2.75	2.65	2.64	2.64	2.64	F _{R2}	4500		
Rt	32					28												30		F _{A2}	4000
Td	0.96					0.93												α _{max}		8'	10'

Pag. Page Seite

40

EP 155																		Stadi Steps Stufenzahl			
Stadi Steps Stufenzahl	1					2															
i	3	4	5	7	10	9	12	15	16	20	25	28	35	40	50	70	100	1	2		
T _{2N}	240	320	380	300	220	320	400	500	500	500	500	500	500	500	500	350	250	n _{1nom}	3000		
T _{2A}	420	540	600	480	400	480	600	750	750	750	750	750	750	750	750	560	460	n _{1max}	4000		
T _{2S}	880	1140	1260	1000	850	1000	1250	1500	1500	1500	1500	1500	1500	1500	1500	1120	920	LpA	< 70		
J _{min}	6.97	4.45	3.57	2.86	2.49	6.84	6.55	6.46	4.22	4.16	3.38	2.78	2.76	2.45	2.44	2.44	2.43	Lh	20000		
J _{max}	13.59	11.07	10.19	9.48	9.11	13.46	13.18	13.08	10.84	10.78	10.00	9.40	9.38	9.07	9.06	9.06	9.05	F _{R2} (AA) F _{R2} (TT)	6500 5300		
Rt	60					50												60		F _{A2} (AA) F _{A2} (TT)	3250 2650
Td	0.96					0.93												α _{max}		8'	10'

Pag. Page Seite

42

Simbologia

Symbols

Verwendete Symbole

α_{\max}	[arcmin]	Gioco angolare standard	<i>Standard backlash</i>	Standard Winkelspiel
C	—	Coefficiente di dispersione termica	<i>Loss of heat coefficient</i>	Wärmeverlustkoeffizient
F_{A2}	[N]	Carico assiale in uscita [N] a 300min ⁻¹	<i>Output axial load [N] at 300min⁻¹</i>	Axiallast an der Abtriebswelle bei 300min ⁻¹
fc	—	Fattore di ciclo	<i>Cycle factor</i>	Zyklusfaktor
F_{R2}	[N]	Carico radiale nominale in uscita [N] a 300min ⁻¹	<i>Rated output radial load [N] at 300min⁻¹</i>	Nenn-Radiallast an der Abtriebswelle bei 300min ⁻¹
f_v	—	Fattore di ventilazione	<i>Ventilation factor</i>	Lüftungsfaktor
i	—	Rapporto di riduzione nominale	<i>Nominal ratio</i>	Nenn-Untersetzungverhältnis
J	[kg.cm ²]	Momento d'inerzia riferito all'albero entrata	<i>Moment of inertia referred to input shaft</i>	Trägheitsmoment bzw. Antriebswelle
KU, KM	—	Coefficiente di utilizzo	<i>Duty coefficient</i>	Anwendungskoeffizient
L_h	[h]	Durata cuscinetti	<i>Bearing life</i>	Lebensdauer der Lager
LpA	dB(A)	Livello di rumorosità dB(A) a 3000 min ⁻¹	<i>Noise level dB(A) at 3000 min⁻¹</i>	Geräuschpegel dB(A) bei 3000 min ⁻¹
n_{1 max}	[min ⁻¹]	Velocità massima in entrata	<i>Maximum input speed</i>	Maximale Eingangsrehzahl
n_{1 nom}	[min ⁻¹]	Velocità nominale in entrata	<i>Nominal input speed</i>	Nenn-Eingangsrehzahl
n_{1E}	[min ⁻¹]	Velocità media in ingresso	<i>Average input speed</i>	Durchschnittsrehzahl am Antrieb
n_{2E}	[min ⁻¹]	Velocità di rotazione media in uscita	<i>Average rotation speed at output</i>	Durchschnittsrehzahl am Abtrieb
n_{2N}	[min ⁻¹]	Velocità di rotazione nominale in uscita	<i>Rated rotation speed at output</i>	Nennrehzahl am Abtrieb
P₀	[W]	Potenza persa a vuoto	<i>Loadless friction power</i>	Verlustleistung ohne Last
P₁	[W]	Potenza persa proporzionale alla potenza applicata	<i>Friction power proportional to the applied power</i>	Verlustleistung proportional zu der angewandten Leistung
Rd	—	Rendimento dinamico	<i>Dynamic efficiency</i>	Dynamischer Wirkungsgrad
R_t	[Nm / arcmin]	Rigidità torsionale	<i>Torsional stiffness</i>	Drehfestigkeit
T₀	[°C]	Temperatura ambiente	<i>Ambient temperature</i>	Umgebungstemperatur
T_{max}	[°C]	Temperatura massima ammessa di funzionamento	<i>Max. permitted temperature of operation</i>	Max. zulässige Betriebstemperatur
T_{1AMOT}	[Nm]	Massima coppia di accelerazione del motore	<i>Max. acceleration torque of motor</i>	Maximales Beschleunigungsdrehmoment des Motors
T_{1E}	[Nm]	Coppia media in entrata	<i>Average torque at input</i>	Durchschnittsdrehmoment am Antrieb
T_{1n}	[Nm]	Coppia nominale del motore	<i>Motor rated torque</i>	Nenn Drehmoment des Motors
T_{2A}	[Nm]	Massima coppia di accelerazione in uscita	<i>Max. acceleration torque at output</i>	Maximales Beschleunigungsdrehmoment am Abtrieb
T_{2E}	[Nm]	Coppia media in uscita	<i>Average torque at output</i>	Durchschnittsdrehmoment am Abtrieb
T_{2N}	[Nm]	Coppia nominale intermittente in uscita	<i>Rated intermittent output torque</i>	Nenn-Abtriebsmoment (im Aussetzbetrieb)
T_{2S}	[Nm]	Coppia massima di emergenza in uscita	<i>Maximum emergency output torque</i>	Max. Notmoment am Abtrieb
τC	[s]	Costante di tempo	<i>Time constant</i>	Zeitkonstante
T_s	[°C]	Temperatura massima di equilibrio	<i>Maximum temperature of equilibrium</i>	Max. Gleichgewichtstemperatur
Zh	[1/h]	Numero di cicli ora	<i>Number of cycles per hour</i>	Zyklenzahl pro Stunde

1.0	RIDUTTORI EPICICLOIDALI SERIE REP	PLANETARY GEARBOXES REP SERIES	PLANETENGETRIEBE SERIE REP	
1.1	Caratteristiche	<i>Characteristics</i>	Merkmale	6
1.2	Designazione	<i>Designation</i>	Bezeichnung	7
1.3	Selezione	<i>Selection</i>	Getriebeauswahl	7
1.4	Verifica termica	<i>Temperature check</i>	Temperaturprüfung	10
1.5	Gioco angolare	<i>Backlash</i>	Winkelspiel	12
1.6	Carichi radiali e assiali su albero lento	<i>Radial and axial loads on output shaft</i>	Radial-und Axiallasten an der Ausgangswelle	13
1.7	Lubrificazione	<i>Lubrication</i>	Schmierung	13
1.8	Momento d'inerzia	<i>Moments of inertia</i>	Trägheitsmoment	14
1.9	Dati tecnici	<i>Technical data</i>	Technische Daten	16
1.10	Dimensioni	<i>Dimensions</i>	Abmessungen	16
1.11	Istruzioni per il montaggio del motore	<i>Instructions for the motor assem- bling</i>	Anleitung für Motoranbau	24



1.1 Caratteristiche

La serie di riduttori epicicloidali REP è il risultato di un ottimo rapporto tra economicità del prezzo e garanzia di precisione delle caratteristiche di funzionamento. I nostri riduttori sono stati realizzati per un'utilizzo prevalente sulle seguenti applicazioni:

- Macchine utensili
- Macchine per la lavorazione del legno
- Linee transfer
- Macchine da stampa
- Macchine automatiche per confezionamento ed imballaggio
- Automazioni
- Manipolatori
- Macchine serigrafiche
- Guide lineari

La gamma dei riduttori REP è costituita da 4 grandezze (075, 100, 125 e 150), a 1, 2 e 3 stadi di riduzione, ognuna con due o tre tipi di alberi uscita (AU...) e flange uscita di tipo FLT e FLQ.

Corpo: costruito in acciaio speciale da nitrurazione, garantisce robustezza e una elevata affidabilità nel tempo.

Flange: le flange in entrata ed in uscita sono costruite in alluminio e sono disponibili in molteplici varianti costruttive.

Alberi: sono costruiti in acciaio legato bonificato.

Ingranaggi: in acciaio legato da cementazione e tempra, con dentature rettificata.

Cuscinetti: di elevata qualità opportunamente dimensionati per garantire elevate durate e silenziosità di funzionamento.

1.1 Characteristics

The planetary gearbox REP series is the result of the outstanding combination competitive price / precision guaranteed with regard to operating features. Our gearboxes are manufactured for prevailing utilization in the following applications:

- *Machine tools*
- *Woodworking machines*
- *Transfer machines*
- *Printing machines*
- *Automatic packing & packaging machines*
- *Automations*
- *Mechanical hands*
- *Silk-screen process machines*
- *Linear guides*

The REP series is available in 4 sizes (075, 100, 125 and 150), with 1, 2 or 3 reduction stages, with two or three types of output shaft (AU...) and two types of output flange (FLT and FLQ).

Housing: made of special nitrided steel to assure strength, high reliability and long life.

Flanges: input and output flanges made of aluminium and available in several versions.

Shafts: made of hardened and tempered alloy steel.

Gears: made of casehardened and tempered alloy steel, with ground toothings.

Bearings: high quality and suitably sized to assure long life and noiseless working.

1.1 Merkmale

Die REP Serie von Planetengetrieben ist das Ergebnis des hervorragenden Beziehung guter Preis / garantierte Präzision der Betriebseigenschaften. Unsere Getriebe sind für überwiegende Verwendung in der folgenden Applikationen hergestellt:

- Werkzeugmaschinen
- Holzbearbeitungsmaschinen
- Transfermaschinen
- Druckmaschinen
- Automatische Verpackungsmaschinen
- Automation
- Manipulatoren
- Siebdruckmaschinen
- Linearführungen

Die REP Serie ist in 4 Größen (075, 100, 125 und 150) mit 1, 2 oder 3 Untersetzungsstufen, mit zwei oder drei Typen von Abtriebswellen (AU...) und zwei Typen von Abtriebsflanschen (FLT und FLQ) verfügbar.

Gehäuse: aus Spezial-Nitrierstahl. Garantiert Robustheit und dauerhaft hohe Zuverlässigkeit.

Ein- u. Ausgangsflansche: aus Aluminium, in zahlreichen Varianten lieferbar.

Wellen: aus vergütetem Legierungsstahl.

Zahnräder: aus gehärteten Einsatzstahl mit geschliffenen Zahnflanken.

Lager: sind hochwertig und zweckmäßig bemessen, um eine lange Lebensdauer und einen geräuscharmen Lauf zu garantieren.

1.2 Designazione

1.2 Designation

1.2 Bezeichnung

Riduttore epicicloidale Planetary gearbox Planetengetriebe	Grandezza Size Größe	Numero di stadi Steps Untersetzungsstufen	Coassiale Coaxial Koaxial	Rapporto di riduzione Ratio Untersetzungsverhältnis	Albero uscita Output shaft Durchmesser Abtriebswelle	Flangia uscita Output flange Ausgangsfiansch	Albero entrata Input shaft Durchmesser Eingangswelle	Flangia in entrata Input flange Eingangsfiansch	Classe di precisione Precision class Präzisionsklasse
REP	075	2	C	100	AU16	FLT	AE12	P03	P
	075 100 125 150	1 2 3	C	3 - 343	Vedi tabelle See tables Siehe Tab.	FLT FLQ	Vedi tabelle See tables Siehe Tab.	Vedi tabelle See tables Siehe Tab.	

1.3 Selezione

Verifica meccanica

La selezione dei riduttori epicicloidali REP deve essere effettuata valutando se il servizio è intermittente o continuo. Noto il ciclo di lavoro:

1.3 Selection

Mechanical check

The selection of the REP planetary gearbox depends on whether the duty is continuous or intermittent. The working cycle being:

1.3 Getriebeauswahl

Mechanische Prüfung

Bei der Wahl des REP Planetengetriebes soll es berücksichtigt werden, ob es um Aussetz- oder Dauerbetrieb handelt. Bei bekannten Arbeitszyklus:

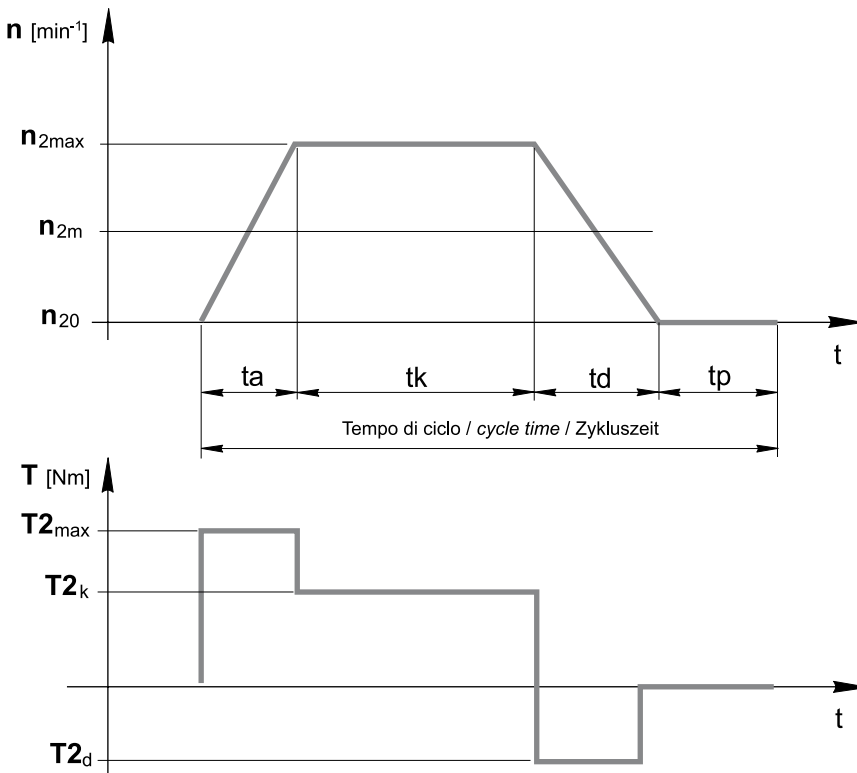

n_{2max} [min^{-1}]	Velocità massima Max. speed Max. Drehzahl
n_{2m} [min^{-1}]	Velocità media Average speed Durchschnittsdrehzahl
n_{20} [min^{-1}]	Velocità zero (motore fermo) Zero speed (motor off) Null Drehzahl (stillstehender Motor)
t_a [s]	Tempo di accelerazione Acceleration time Beschleunigungszeit
t_k [s]	Tempo di funzionamento a regime Standard time of operation Standardbetriebszeit
t_d [s]	Tempo di decelerazione Deceleration time Verzögerungszeit
t_p [s]	Tempo di pausa Pause time Pausenzeit
T_{2max} [Nm]	Coppia massima Max. torque Maximaldrehmoment
T_{2k} [Nm]	Coppia a regime Standard torque Standardbetriebsdrehmoment
T_{2d} [Nm]	Coppia in decelerazione Decelerating torque Verzögerungsdrehmoment

si definiscono i coefficienti di utilizzo KU, KM secondo le seguenti formule:

calculate KU, KM duty coefficients with the following formulae:

darf der Anwendungskoeffizient KU, KM wie folgt kalkuliert werden:

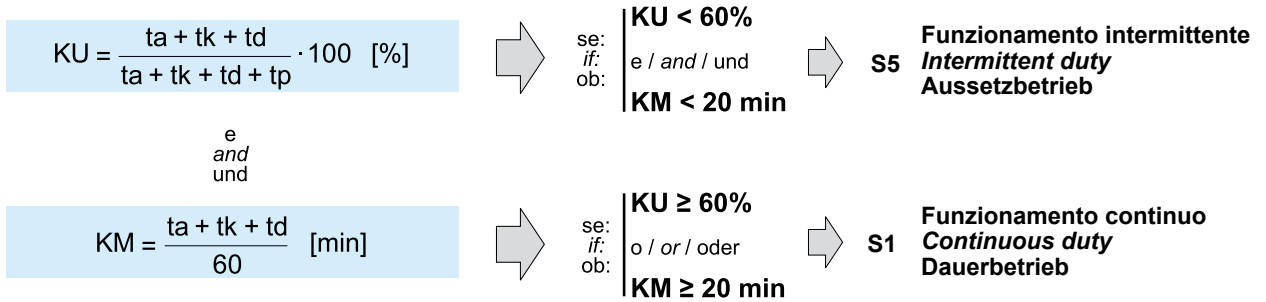

Funzionamento intermittente

Intermittent duty

Aussetzbetrieb

In questo caso, deve essere verificata la seguente relazione:

In case of intermittent duty, the following equation should be checked:

Bei Aussetzbetrieb soll die folgende Relation festgestellt werde

1) $T_{2A} \geq T_{1AMOT} \cdot i \cdot f_c \cdot Rd$

2) $T_{2N} \geq T_{1K}$

Dove :

T_{2A} = massima coppia di accelerazione in uscita garantita dal riduttore [Nm] (vedi tabelle delle prestazioni)

T_{2N} = coppia nominale intermittente in uscita ammessa dal riduttore [Nm] (vedi tabelle delle prestazioni)

T_{1AMOT} = massima coppia di accelerazione del motore [Nm]

i = rapporto di riduzione

f_c = fattore di ciclo (vedi tabella 1)

Rd = rendimento dinamico (vedi tabella delle prestazioni)

T_{1k} = Coppia a regime

Where:

T_{2A} = max. acceleration torque at output guaranteed by the gearbox [Nm] (see tables of performance)

T_{2N} = rated intermittent allowable torque at output [Nm] (see tables of performance)

T_{1AMOT} = max. acceleration torque of motor [Nm]

i = reduction ratio

f_c = cycle factor (see table 1)

Rd = dynamic efficiency (see table of performance)

T_{1k} = Standard torque

Wobei:

T_{2A} = maximales Beschleunigungsdrehmoment am Abtrieb, das von Getriebe garantiert wird [Nm] (siehe Leistungstabellen)

T_{2N} = Zulässiges intermittierendes Nenndrehmoment am Abtrieb [Nm] (siehe Leistungstabelle)

T_{1AMOT} = maximales Beschleunigungsdrehmoment des Motors [Nm]

i = Übersetzungsverhältnis

f_c = Zyklusfaktor (siehe Tabelle 1)

Rd = dynamischer Wirkungsgrad (siehe Leistungstabelle)

T_{1k} = Standardbetriebsdrehmoment

Infine, si confronti il valore della velocità in entrata massima consentita (n_{1max} , v. tabella delle prestazioni) con la massima velocità di rotazione raggiunta in entrata dall'applicazione (n'_{1max}). Deve essere:

Finally, the max. allowed input speed (n_{1max} , see table of performance) has to be compared with the max. rotation speed reached by the application at input (n'_{1max}). The result has to be as follows:

Schließlich sollen das zulässige Maximaldrehzahl am Antrieb (n_{1max} , siehe Leistungstabelle) und das in der Applikation erreichten Maximaldrehzahl am Antrieb verglichen werden (n'_{1max}). Das Ergebnis soll wie folgt sein:

3) $n_{1max} \geq n'_{1max}$

Funzionamento continuo

Continuous duty

Continuous duty

In questo caso devono essere verificate le seguenti relazioni:

In case of continuous duty the following equations have to be checked:

Bei Dauerbetrieb sind die folgenden Relationen zu prüfen:

1) $T_{2N} \geq T_{1AMOT} \cdot i \cdot f_c \cdot f_u \cdot Rd$

2) $n_{2N} \geq n_{2E}$

3) $n_{1max} \geq n'_{1max}$

Dove :

T_{2A} = massima coppia di accelerazione in uscita garantita dal riduttore [Nm] (vedi tabelle delle prestazioni)
 T_{1AMOT} = massima coppia di accelerazione del motore [Nm]
 i = rapporto di riduzione
 f_c = fattore di ciclo (vedi tabella 1)
 Rd = rendimento dinamico (vedi tabella delle prestazioni)
 T_{2N} = coppia nominale intermittente in uscita ammessa dal riduttore [Nm] (vedi tabelle delle prestazioni)
 T_{2E} = coppia nominale intermittente in uscita ammessa dal riduttore [Nm]

Where:

T_{2A} = *max. acceleration torque at output guaranteed by the gearbox [Nm] (see tables of performance)*
 T_{1AMOT} = *max. acceleration torque of motor [Nm]*
 i = *reduction ratio*
 f_c = *cycle factor (see table 1)*
 Rd = *dynamic efficiency (see table of performance)*
 T_{2N} = *rated intermittent allowable torque at output [Nm] (see tables of performance)*
 T_{2E} = *average torque at output [Nm], to be calculated with the following formula:*

Wobei:

T_{2A} = maxiales Beschleunigungsdrehmoment am Abtrieb, das von Getriebe garantiert wird [Nm] (siehe Leistungstabellen)
 T_{1AMOT} = maxiales Beschleunigungsdrehmoment des Motors [Nm]
 i = Übersetzungsverhältnis
 f_c = Zyklusfaktor (siehe Tabelle 1)
 Rd = dynamischer Wirkungsgrad (siehe Leistungstabelle)
 T_{2N} = Zulässiges intermittierendes Nenn Drehmoment am Abtrieb [Nm] (siehe Leistungstabelle)
 T_{2E} = Durchschnittsdrehmoment am Abtrieb [Nm] wird mit der folgenden Formel kalkuliert:

$$n_{2E} = \frac{n_{2m} \cdot t_a + \dots + n_{2n} \cdot t_n}{t_a + \dots + t_n} \quad [\text{min}^{-1}]$$

n_{2N} = velocità di rotazione nominale in uscita [min^{-1}] (vedi tabelle delle prestazioni: $n_{2N} = n_{1nom}/i$)
 n_{2E} = velocità di rotazione media in uscita [min^{-1}] e vale:

n_{2N} = *rated rotation speed at output [min^{-1}] (see tables of performance $n_{2n} = n_{1nom}/i$)*
 n_{2E} = *average rotation speed at output [min^{-1}]*

n_{2N} = Nenndrehzahl am Abtrieb [min^{-1}] (siehe Leistungstabelle $n_{2n} = n_{1nom}/i$)
 n_{2E} = Durchschnittsdrehzahl am Abtrieb, wird wie folgt kalkuliert:

Determinazione di f_c

Il valore del fattore di ciclo f_c dipende dal numero di cicli ora Z_h , dove:

Calculation of f_c

The value of f_c cycle factor depends on the number of cycles per hour Z_h :

Berechnung von f_c

Der Wert von f_c Zyklusfaktor hängt von der Zyklenzahl pro Stunde Z_h ab:

$$Z_h = \frac{3600}{t_a + t_k + t_d + t_p} \quad [1/h]$$

Una volta determinato Z_h , consultando la seguente tabella, si ricava f_c da introdurre nelle formule precedenti:

Once Z_h is thus calculated, use the following table to select f_c :

Nachdem Z_h kalkuliert worden ist, dann kann f_c aus der folgenden Tabelle ausgelesen werden:

Tab. 1	Z_h		
	1000	1000 - 2000	2000 - 3000
f_c	1	1.2 - 1.5	1.5 - 2

Determinazione di f_u

Il valore del fattore di utilizzo f_u dipende dal rapporto tra il tempo di funzionamento ed il tempo ciclo:

Calculation of f_u

The value of the utilization factor f_u depends on the ratio between the running time and the cycle time:

Berechnung von f_u

Der Wert von f_u Anwendungsfaktor hängt von dem Verhältnis zwischen der Betriebszeit und der Zykluszeit:

f_u	$KU < 60\%$	$60\% \leq KU < 80\%$	$KU \geq 80\%$
		1	1.25

1.4 Verifica termica

Si deve individuare il valore del momento torcente massimo / potenza massima, applicabile, in modo continuativo, in ingresso al riduttore epicicloidale, tale per cui la temperatura del riduttore stesso non superi $T_{max}=95^{\circ}C$ (massimo valore di temperatura raggiungibile nel caso di applicazioni standard). Tali valori devono risultare maggiori rispetto al momento torcente / potenza realmente applicati.

I massimi valori di coppia motrice / potenza applicabili in entrata al riduttore, in servizio continuativo, sono ricavabili dalle seguenti tabelle (tab. 2, tab. 3), in funzione del numero di stadi di riduzione e del numero di giri in entrata, considerata una temperatura ambiente $T_0=20^{\circ}C$.

1.4 Temperature check

It is necessary to determine the max. torque/max. power applicable at the planetary gearbox input, continuous duty, so that gearbox temperature does not exceed $T_{max}=95^{\circ}C$ (maximum permitted temperature for standard applications). The max applicable values have to be higher than the torque/power actually applied. The maximum values of driving torque/power applicable at gearbox input, continuous duty, are listed in the following tables (table 2 and 3), depending on number of reduction stages, number of revolutions at input and considering an ambient temperature $T_0 = 20^{\circ}C$.

1.4 Temperaturprüfung

Es muss berechnet werden, welches Maximaldrehmoment /welche Maximalleistung am Antrieb des Planetengetriebes im Dauerbetrieb angewendet werden darf, ohne dass die Getriebetemperatur über $T_{max}=95^{\circ}C$ steigt (zulässige Maximaltemperatur bei Standardanwendungen). Der berechnete Wert muss höher als der wirklich angewendete Wert die maximal Werte von Drehmoment / Leistung sein.

Die Maximalwerte von Drehmoment / Leistung (Dauerbetrieb) werden in den folgenden Tabellen (Tab.2 und Tab.3) angegeben. Die Werte hängen von Zahl der Übersetzungsstufen und der Umdrehungen am Antrieb ab dabei wird eine Umgebungstemperatur $T_0=20^{\circ}C$ berücksichtigt.

Potenza / Power / Leistung [kW]
(Limite termico / Thermal capacities / Temperaturgrenze)

Tab. 2	Stadi Steps Stufenzahl	n_1 [min ⁻¹]			
		900	1400	2800	3600
REP 75	1	4.5	4.4	4.0	3.5
	2	2.5	2.3	2.0	1.8
	3	1.9	1.8	1.5	1.4
REP 100	1	6.0	6.0	4.6	3.8
	2	3.5	3.3	2.5	2.0
	3	2.7	2.5	2.0	1.6
REP 125	1	9.0	8.5	6.2	4.7
	2	5.5	4.8	3.4	2.5
	3	4.0	3.7	2.8	2.0
REP 150	1	11.0	10.0	5.6	2.8
	2	6.1	5.5	2.6	1.0
	3	4.7	4.3	2.3	0.9

Coppia / Torque / Drehmoment [Nm]
(Limite termico / Thermal capacities / Temperaturgrenze)

Tab. 3	Stadi Steps Stufenzahl	n_1 [min ⁻¹]			
		900	1400	2800	3600
REP 75	1	48	30	14	9
	2	27	16	7	5
	3	20	12	5	4
REP 100	1	64	41	16	10
	2	37	23	9	5
	3	29	17	7	4
REP 125	1	96	58	21	12
	2	58	33	12	7
	3	42	25	10	5
REP 150	1	117	68	19	7
	2	65	38	9	3
	3	50	29	8	2

Nel caso in cui l'applicazione preveda l'utilizzo di una coppia motrice / potenza maggiore del valore limite riportato nella tabella precedente, occorre valutare il massimo tempo di utilizzo, t_{max} (s), del riduttore, in servizio continuo, affinché la temperatura non superi il valore $T_{max}=95^{\circ}C$.

A tal fine: il massimo tempo di utilizzo, t_{max} , è ricavabile dalla seguente relazione:

In case the application requires a driving torque/power higher than the max. permitted values reported in the table above, it is necessary to calculate the maximum length of operation, t_{max} (s), of the gearbox in continuous duty so that temperature does not exceed $T_{max}=95^{\circ}C$.

The max. duration of operation, t_{max} , is to be calculated as follows:

Falls der verlangte Wert von Drehmoment / Leistung höher als der in den o.g. Tabellen angegebenen Wert ist, ist es notwendig, die maximale Anwendungsdauer t_{max} (s) im Dauerbetrieb zu bestimmen, damit die Temperatur unter $T_{max}=95^{\circ}C$ bleibt.

Die maximale Anwendungsdauer t_{max} ist wie folgt zu berechnen:

$$t_{max} = -\tau_c \cdot \ln \frac{T_s - T_{MAX}}{T_s - T_0} \quad [s]$$

Dove :

T_{MAX} = 95 °C (temperatura massima raggiungibile dal riduttore)
 T_0 = temperatura ambiente (°C)
 τ_c = costante di tempo (s) ricavabile consultando la seguente tabella (Tab. 4):

Where:

T_{MAX} = 95 °C (maximum permitted temperature)
 T_0 = ambient temperature (°C)
 τ_c = time constant (s), as reported in the following table (Tab. 4):

Wobei:

T_{MAX} = 95 °C (zulässige Maximaltemperatur des Getriebes)
 T_0 = Umgebungstemperatur (°C)
 τ_c = Zeitkonstante, aus der folgenden Tabelle erhältlich (Tab. 4):

Stadi / Steps / Stufenzahl	REP 75			REP 100			REP 125			REP 150		
	1	2	3	1	2	3	1	2	3	1	2	3
τ_c (s)	Costante di tempo / Time constant / Zeitkonstante											
	551	655	748	747	939	1111	1255	1590	1891	1858	2369	2824

T_s = temperatura massima (°C) alla quale il riduttore tenderà a stabilizzarsi nel caso in cui sia applicata in ingresso la potenza P1, in condizioni di funzionamento continuo. Il valore di T_s è ricavabile dalla seguente formula:

T_s = maximum temperature (°C) at which the gearbox will tend to stabilize in case P1 power is applied at input, continuous duty. Calculate T_s value with the following formula:

T_s = maximale Temperatur (C°), auf die das Getriebe sich stabilisieren wird, falls im Dauerbetrieb P1 Antriebsleistung angewendet wird. T_s ist mit der folgenden Formel zu berechnen:

$$T_s = T_0 + \frac{P_0 + P_{\eta}}{C \cdot f_v} \quad [^{\circ}\text{C}]$$

in cui:

P_0 = potenza persa a vuoto (W), ricavabile dalla seguente tabella (Tab. 5) in funzione della grandezza del riduttore, del numero degli stadi di riduzione e della velocità di rotazione in ingresso

Where:

P_0 = loadless friction power (W), reported in the following table (Tab. 5), depending on gearbox size, number of reduction stages and input rotation speed

Wobei:

P_0 = Verlustleistung ohne Last (W), ist aus der folgenden Tabelle zu entnehmen und hängt von Getriebegröße, Stufenzahl und Antriebsdrehzahl ab.

	$n_1 = 900$ [min ⁻¹]			$n_1 = 1400$ [min ⁻¹]			$n_1 = 2800$ [min ⁻¹]			$n_1 = 3600$ [min ⁻¹]		
	Stadi / Steps / Stufenzahl											
	1	2	3	1	2	3	1	2	3	1	2	3
	P_0 - Potenza persa a vuoto / Loadless friction power / Verlustleistung ohne Last [W]											
REP 75	3	4	5	6	8	8	14	18	19	20	26	27
REP 100	7	9	9	12	15	16	30	38	39	42	53	55
REP 125	12	15	16	22	27	28	56	71	73	81	101	104
REP 150	22	27	28	39	50	51	106	132	136	151	191	196

C = Coefficiente di dispersione termica, ricavabile dalla seguente tabella (Tab.6), in funzione della grandezza del riduttore

C = loss of heat coefficient, listed in the following table (Tab. 6), according to gearbox size.

C = Wärmeverlustkoeffizient, wird in der folgenden Tabelle (Tab.6) angegeben und hängt von Getriebegröße ab.

	Stadi / Steps / Stufenzahl		
	1	2	3
	C - Coefficiente di dispersione termica / loss of heat coefficient / Wärmeverlustkoeffizient		
REP 75	1.024	1.120	1.248
REP 100	1.410	1.620	1.800
REP 125	2.175	2.450	2.725
REP 150	2.680	3.020	3.380

f_v = fattore di ventilazione
1.45 con ventilazione forzata efficace con ventola dedicata
1.25 con ventilazione forzata secondaria ad altri dispositivi (pulegge, ventole motore, ecc.)

f_v = ventilation factor
1.45 for forced ventilation effective with special fan
1.25 for forced ventilation secondary to other devices (pulleys, motor fans, etc.)

f_v = Lüftungsfaktor
1.45 für wirksame Drücklüftung mit Sonderlaufrad
1.25 für Drücklüftung zweitrangig zu anderen Vorrichtungen (Scheiben, Motorlaufräder, u.s.w.)

1 refrigerazione naturale (situazione standard)
0.5 in ambiente chiuso e ristretto (carter)

1 for natural cooling (standard situation)
0.5 in a close and narrow place (housing)

1 für Naturlüftung (Standardsituation)
0.5 in geschlossenem und engem Raum (Gehäuse)

P_{η} = potenza persa proporzionale alla potenza applicata (W)
P1 . 0.015 (W) nel caso di 1 stadio di riduzione
P1 . 0.03 (W) nel caso di 2 stadi di riduzione
P1 . 0.044 (W) nel caso di 3 stadi di riduzione

P_h = friction power proportional to the applied power (W)
P1 . 0.015 (W) in case of 1 reduction stage
P1 . 0.03 (W) in case of 2 reduction stages
P1 . 0.044 (W) in case of 3 reduction stages

P_h = Verlustleistung proportional zu der angewandten Leistung (W)
P1 . 0.015 (W) im Falle von 1 Übersetzungsstufe
P1 . 0.03 (W) im Falle von 2 Übersetzungsstufen
P1 . 0.044 (W) im Falle von 3 Übersetzungsstufen

P1 è la potenza applicata in ingresso, da esprimersi in W. Nel caso in cui sia invece nota la coppia motrice applicata in ingresso T1, in Nm, si ricava il corrispondente valore di potenza, attraverso la relazione:

P1 is the power applied at gearbox input and is expressed in W. In case one only knows T1 (driving torque applied at input) expressed in Nm, the corresponding power value can be obtained as follows:

P1 ist die am Getriebeantrieb angewandte Leistung und wird in W ausgedrückt. Falls nur T1 (Antriebsdrehmoment in Nm) bekannt ist, dann ist den entsprechenden Leistungswert mit der folgenden Formel zu berechnen:

$$P1 = \frac{T1 \cdot n_1}{9550} \cdot 1000 \text{ [W]}$$

con n_1 velocità di rotazione in ingresso in min^{-1} .

Se il ciclo di lavoro è variabile nel tempo, si determinino i valori della coppia media $T1_E$ e velocità media in ingresso $n1_E$ secondo le seguenti formule:

where n_1 is the input rotation speed in min^{-1} .

If the operation cycle changes in time, the values of $T1_E$ (average torque) and $n1_E$ (average input speed) can be determined with the following formulae:

Dabei ist n_1 die Antriebsdrehzahl in min^{-1} . Falls der Betriebszyklus in Laufe der Zeit wechselnd ist, dann sind Durchschnittsdrehmoment $T1_E$ und Durchschnittsdrehzahl am Antrieb $n1_E$ mit der folgenden Formel zu berechnen:

$$T1_E = \sqrt[3]{\frac{T1_{MAX}^3 \cdot n_{1m} \cdot ta + \dots + T1_n^3 \cdot n_{1n} \cdot tn}{ta \cdot n_{1m} + \dots + tn \cdot n_{1n}}} \text{ [Nm]}$$

$T1_n, n1_n, t_n$ = valori riferiti allo step ennesimo
 = values referred to nth step.
 = Werte mit Bezug auf n-te Stufe.

$$n1_E = \frac{n_{1m} \cdot ta + \dots + n_{1n} \cdot tn}{ta + \dots + tn} \text{ [min}^{-1}\text{]}$$

1.5 Gioco Angolare (α_{max})

Gioco massimo [arcmin] misurato sull'albero uscita, con albero entrata bloccato applicando una coppia pari al 2% della coppia nominale.

1.5 Backlash (α_{max})

Max. backlash measured on output shaft with torque equal to 2% of the nominal torque value with input shaft blocked

1.5 Winkelspiel (α_{max})

Maximales Winkelspiel [arcmin], gemessen an der Abtriebswelle bei blockierter Eingangswelle mit Drehmoment gleich 2% des Nennmoments.

1.6 Carichi radiali e assiali su albero lento

Nella tabella delle prestazioni sono indicati i valori, espressi in N, dei carichi assiali e radiali ammissibili alle diverse velocità per una durata dei cuscinetti di 20000 ore. Il carico radiale F_{R2} si considera applicato ad una distanza dalla battuta pari alla metà della lunghezza dell'albero lento. Per distanze y diverse, è possibile calcolare il nuovo carico massimo ammissibile F_{R2Y} utilizzando formula e coefficienti indicati nella tabella.

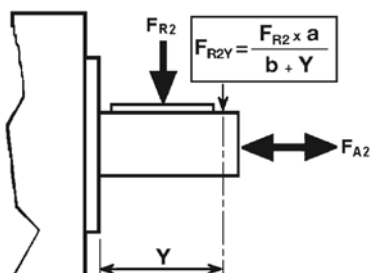

1.6 Radial and axial loads on output shaft

The table of performances shows admissible axial and radial load values expressed in N for different speeds and for a bearing life of 20000 hours. Radial load F_{R2} calculations have been based on loads applied to halfway the output shaft extension. For different y distance it is possible to calculate the new maximum admissible load by using formula and coefficient shown in the table.

1.6 Radial- und axiallast an der Ausgangswelle

Die Leistungstabelle enthält die in N ausgedrückten Werte der Axial- und Radiallasten für verschiedene Umdrehungszahlen. Diesen Werten liegt eine Lebensdauer der Lager von 20000 Stunden zugrunde. Die Radiallast F_{R2} greift hierbei auf der Mitte der Abtriebswelle an. Falls Y -distanz anders ist, ist die Zulässige radiallast F_{R2Y} mit den in der Tabelle angegebenen formel und Koeffizient zu berechnen:

	REP 75	REP 100	REP 125	REP 150
a	46	55	85	102
b	30	37	51	61

1.7 Lubrificazione

I riduttori REP sono forniti completi di lubrificante a vita pertanto non necessitano di manutenzione. In fase di ordine specificare la posizione di montaggio.

1.7 Lubrication

REP gearboxes are supplied filled with long-life lubricant and do not require any maintenance. When ordering it is important to specify the exact mounting position.

1.7 Schmierung

Die REP Planetengetriebe werden inklusiv Dauerschmierung geliefert und sind wartungsfrei. Bei der Bestellung bitte die Einbauposition angeben

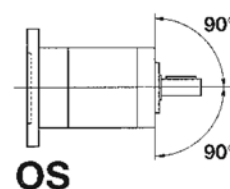
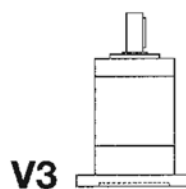
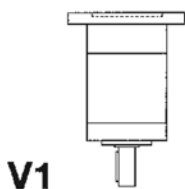
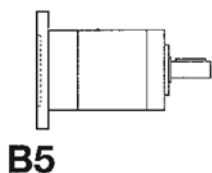

1.8 Momento d'inerzia J
[kg·cm²]

1.8 Moment of inertia J
[kg·cm²]

1.8 Trägheitsmoment J
[kg·cm²]

REP 075											
Albero entrata / Input shaft / Antriebswelle											
Stadi Steps Stufenzahl	i	6	6.35	7	8	9	9.52	11	12	12.7	14
1	3	0.16	0.16	0.16	0.19	0.19	0.19	0.21	0.21	0.21	0.25
	4	0.14	0.14	0.14	0.16	0.16	0.16	0.18	0.19	0.18	0.22
	5	0.12	0.12	0.12	0.14	0.14	0.14	0.16	0.16	0.16	0.20
	6	0.11	0.11	0.11	0.13	0.13	0.13	0.15	0.16	0.16	0.19
2	9	0.16	0.16	0.16	0.19	0.19	0.19	0.21	0.21	0.21	0.25
	12	0.16	0.16	0.16	0.19	0.19	0.18	0.21	0.21	0.21	0.25
	16	0.14	0.14	0.14	0.16	0.16	0.16	0.18	0.18	0.18	0.22
	20	0.12	0.12	0.12	0.14	0.14	0.14	0.16	0.16	0.16	0.20
	24	0.11	0.11	0.11	0.13	0.13	0.13	0.15	0.16	0.15	0.19
	30	0.11	0.11	0.11	0.13	0.13	0.13	0.15	0.16	0.15	0.19
3	36	0.11	0.11	0.11	0.13	0.13	0.13	0.15	0.16	0.15	0.19
	27	0.16	0.16	0.16	0.19	0.19	0.19	0.21	0.21	0.21	0.25
	36	0.16	0.16	0.16	0.19	0.19	0.19	0.21	0.21	0.21	0.25
	48	0.16	0.16	0.16	0.19	0.19	0.18	0.21	0.21	0.21	0.25
	64	0.14	0.14	0.14	0.16	0.16	0.16	0.18	0.18	0.18	0.22
	80	0.12	0.12	0.11	0.14	0.14	0.14	0.16	0.16	0.16	0.20
	100	0.11	0.11	0.11	0.14	0.14	0.14	0.16	0.16	0.16	0.20
	120	0.11	0.11	0.11	0.13	0.13	0.13	0.15	0.16	0.15	0.19
	144	0.11	0.11	0.11	0.13	0.13	0.13	0.15	0.16	0.15	0.19
	180	0.11	0.11	0.11	0.13	0.13	0.13	0.15	0.16	0.15	0.19
216	0.11	0.11	0.11	0.13	0.13	0.13	0.15	0.16	0.15	0.19	

REP 100									
Albero entrata / Input shaft / Antriebswelle									
Stadi Steps Stufenzahl	i	9	9.52	11	12.7	14	15.87	16	19
1	3	0.47	0.47	0.49	0.49	0.53	0.82	0.82	0.80
	4	0.35	0.35	0.37	0.37	0.41	0.70	0.70	0.69
	5	0.28	0.28	0.30	0.30	0.34	0.63	0.63	0.62
	6	0.26	0.26	0.28	0.28	0.32	0.61	0.61	0.60
2	9	0.48	0.48	0.50	0.51	0.55	0.83	0.83	0.82
	12	0.47	0.47	0.49	0.49	0.53	0.82	0.82	0.81
	16	0.34	0.34	0.36	0.36	0.41	0.69	0.69	0.68
	20	0.28	0.28	0.30	0.30	0.34	0.63	0.63	0.62
	24	0.26	0.26	0.28	0.28	0.32	0.61	0.61	0.59
	30	0.25	0.25	0.27	0.28	0.32	0.61	0.60	0.59
3	36	0.25	0.25	0.27	0.28	0.32	0.60	0.60	0.59
	27	0.49	0.49	0.51	0.51	0.55	0.84	0.84	0.82
	36	0.48	0.48	0.50	0.51	0.55	0.84	0.83	0.82
	48	0.47	0.47	0.49	0.49	0.53	0.82	0.82	0.81
	64	0.34	0.34	0.36	0.36	0.41	0.69	0.69	0.68
	80	0.28	0.28	0.30	0.30	0.34	0.63	0.63	0.62
	100	0.28	0.27	0.30	0.30	0.34	0.63	0.63	0.61
	120	0.25	0.25	0.27	0.28	0.32	0.61	0.60	0.59
	144	0.25	0.25	0.27	0.28	0.32	0.60	0.60	0.59
	180	0.25	0.25	0.27	0.28	0.32	0.60	0.60	0.59
216	0.25	0.25	0.27	0.28	0.32	0.60	0.60	0.59	

I valori dei momenti d'inerzia riportati si riferiscono all'albero entrata.

The moment of inertia values refer to the input shaft.

Die Werte der Trägheitsmoment beziehen sich auf die Antriebswelle.

1.8 Momento d'inerzia J
[kg·cm²]

1.8 Moment of inertia J
[kg·cm²]

1.8 Trägheitsmoment J
[kg·cm²]

		REP 125							
		Albero entrata / Input shaft / Antriebswelle							
Stadi Steps Stufenzahl	i	12.7	14	15.87	16	19	22	24	28
1	3	1.91	1.98	2.26	2.26	2.24	4.95	4.91	5.10
	4	1.18	1.25	1.53	1.53	1.50	4.22	4.18	4.36
	5	0.84	0.91	1.19	1.19	1.16	3.88	3.84	4.02
	7	0.64	0.70	0.99	0.99	0.96	3.67	3.63	3.82
2	9	1.93	1.99	2.28	2.28	2.25	4.97	4.92	5.11
	12	1.85	1.91	2.20	2.20	2.17	4.88	4.84	5.03
	16	1.14	1.21	1.49	1.49	1.47	4.18	4.14	4.33
	20	0.82	0.88	1.17	1.16	1.14	3.85	3.81	4.00
	28	0.62	0.69	0.97	0.97	0.95	3.66	3.62	3.81
	35	0.63	0.69	0.98	0.98	0.95	3.66	3.62	3.81
3	49	0.62	0.69	0.97	0.97	0.95	3.66	3.62	3.81
	36	1.92	1.99	2.27	2.27	2.24	4.96	4.92	5.11
	48	1.84	1.91	2.19	2.19	2.17	4.88	4.84	5.03
	64	1.14	1.21	1.49	1.49	1.46	4.18	4.14	4.32
	80	0.81	0.88	1.16	1.16	1.14	3.85	3.81	4.00
	100	0.80	0.87	1.15	1.15	1.12	3.84	3.80	3.98
	140	0.62	0.68	0.97	0.97	0.94	3.65	3.61	3.80
	196	0.61	0.68	0.96	0.96	0.94	3.65	3.61	3.80
245	0.61	0.68	0.96	0.96	0.93	3.65	3.61	3.79	
343	0.61	0.68	0.96	0.96	0.93	3.65	3.61	3.79	

		REP 150								
		Albero entrata / Input shaft / Antriebswelle								
Stadi Steps Stufenzahl	i	15.87	16	19	22	24	28	32	35	38
1	3	6.58	6.58	6.62	7.57	7.53	11.55	13.38	13.28	12.94
	4	4.64	4.64	4.68	5.63	5.59	9.62	11.44	11.34	11.00
	5	3.64	3.64	3.68	4.63	4.59	8.62	10.45	10.35	10.01
	7	3.05	3.05	3.09	4.04	4.00	8.03	9.86	9.76	9.42
2	9	6.54	6.54	6.58	7.53	7.49	11.51	13.34	13.24	12.90
	12	6.32	6.32	6.36	7.31	7.27	11.30	13.13	13.03	12.69
	16	4.49	4.49	4.53	5.48	5.44	9.47	11.30	11.20	10.86
	20	3.55	3.55	3.59	4.54	4.50	8.53	10.36	10.26	9.92
	28	3.01	3.01	3.05	4.00	3.96	7.98	9.81	9.71	9.37
	35	2.99	2.99	3.03	3.97	3.94	7.96	9.79	9.69	9.35
3	49	2.97	2.97	3.01	3.96	3.92	7.95	9.78	9.68	9.34
	36	6.51	6.51	6.55	7.50	7.46	11.49	13.31	13.21	12.87
	48	6.31	6.31	6.35	7.29	7.26	11.28	13.11	13.01	12.67
	64	4.49	4.48	4.52	5.47	5.44	9.46	11.29	11.19	10.85
	80	3.55	3.54	3.59	4.53	4.50	8.52	10.35	10.25	9.91
	100	3.51	3.51	3.55	4.50	4.46	8.48	10.31	10.21	9.87
	140	2.98	2.98	3.02	3.97	3.93	7.96	9.79	9.69	9.35
	196	2.97	2.97	3.01	3.96	3.92	7.95	9.78	9.68	9.34
245	2.97	2.97	3.01	3.96	3.92	7.95	9.78	9.68	9.34	
343	2.97	2.97	3.01	3.96	3.92	7.95	9.78	9.68	9.34	

I valori dei momenti d'inerzia riportati si riferiscono all'albero entrata.

The moment of inertia values refer to the input shaft.

Die Werte der Trägheitsmoment beziehen sich auf die Antriebswelle.

1.9 Dati tecnici

1.9 Technical data

1.9 Technische Daten

Stadi Steps Stufenzahl	1				2								3									
i	3	4	5	6	9	12	16	20	24	30	36	27	36	48	64	80	100	120	144	180	216	
$n_{1\text{ nom}}$	4000				4500								5000									
$n_{1\text{ max}}$	6000																					
T_{2N}	35	45	35	30	40	50	50	50	50	40	35	40	55	55	55	55	55	55	55	40	35	
T_{2A}	55	65	55	50	60	70	70	70	70	60	55	60	80	80	80	80	80	80	80	60	55	
T_{2S}	110	130	110	100	120	140	140	140	140	120	110	120	150	150	150	150	150	150	150	120	110	
J	Vedi pag. 14 / See page 14 / Siehe auf Seite 14																					
LpA	< 70																					
R _d	0.96				0.93								0.91									
L _h	20000																					
F _{R2}	1400																					
F _{A2}	700																					
R _t	4																					
$\alpha_{\text{ max}}$	4'				6'								8'									
Kg	1.3				1.6								1.9									

i Rapporto di riduzione nominale
 $n_{1\text{ nom}}$ Velocità nominale in entrata [min⁻¹]
 $n_{1\text{ max}}$ Velocità massima in entrata [min⁻¹]
 T_{2N} Coppia nominale intermittente in uscita [Nm]
 T_{2A} Coppia massima di accelerazione in uscita [Nm]
 T_{2S} Coppia massima di emergenza in uscita [Nm]
LpA Livello di rumorosità dB(A) a 3000 min⁻¹
R_d Rendimento dinamico
L_h Durata cuscinetti [h]
F_{R2} Carico radiale nominale in uscita [N] a 300min⁻¹
F_{A2} Carico assiale in uscita [N] a 300min⁻¹
R_t Rigidità torsionale [Nm / arcmin]
 $\alpha_{\text{ max}}$ Gioco angolare massimo [arcmin]
J Momento d'inerzia [kg.cm²]

Nominal ratio
Nominal input speed [min⁻¹]
Maximum input speed [min⁻¹]
Rated intermittent output torque [Nm]
Maximum acceleration output torque [Nm]
Maximum emergency output torque [Nm]
Noise level dB(A) at 3000 min⁻¹
Dynamic efficiency
Bearing life [h]
Rated output radial load [N] at 300min⁻¹
Output axial load [N] at 300min⁻¹
Torsional stiffness [Nm / arcmin]
Maximum backlash [arcmin]
Moment of inertia [kg.cm²]

Nenn-Untersetzungsverhältnis
Nenn-Eingangsdrehzahl [min⁻¹]
Maximale Eingangsdrehzahl [min⁻¹]
Nenn-Abtriebsmoment (im Aussetzbetrieb)[Nm]
Maximales Beschleunigungsmoment am Abtrieb [Nm]
Maximale Überlast am Abtrieb [Nm]
Geräuschpegel dB(A) bei 3000 min⁻¹
Dynamischer Wirkungsgrad
Lebensdauer der Lager [h]
Nenn-Radiallast an der Abtriebswelle bei 300min⁻¹
Axiallast an der Abtriebswelle bei 300min⁻¹
Drehfestigkeit [Nm / arcmin]
Maximale Winkelspiel [arcmin]
Trägheitsmoment [kg.cm²]

1.10 Dimensioni

1.10 Dimensions

1.10 Abmessungen

Dimensioni generali e uscite / General and output dimensions / General-und Abtriebsabmessungen

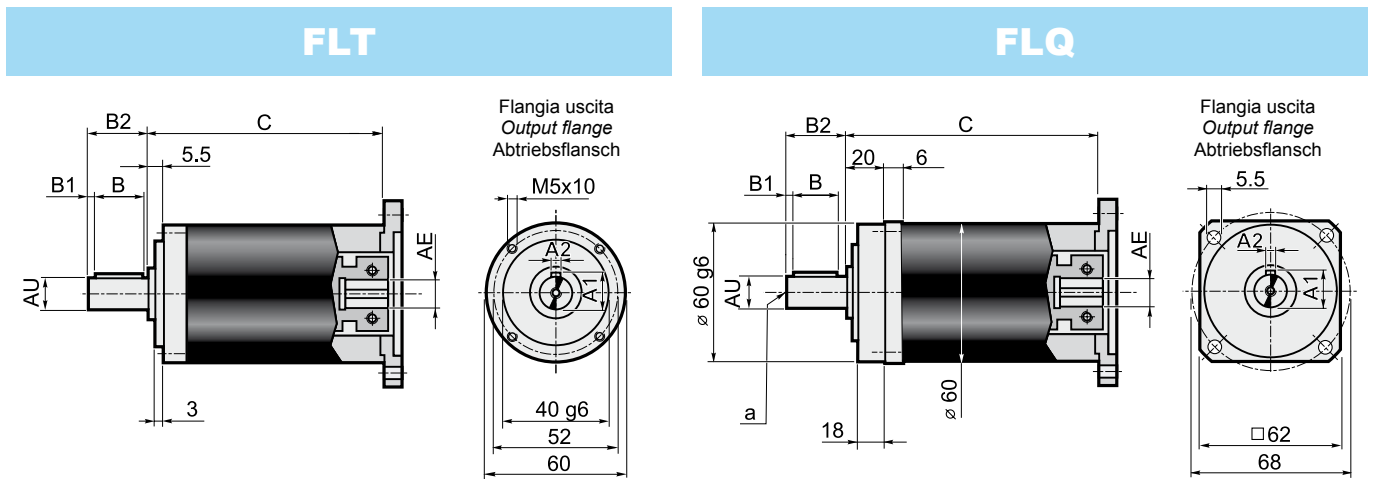

Stadi / Steps / Stufenzahl	1	2	3	
C	86.2	103.9	121.6	AE= 6-6.35-7-8-9-9.52 11-12-12.7-14

	Albero uscita - Output shaft - Abtriebswelle						
	AU j6	A1	A2	B	B1	B2	a
AU12	12	13.5	4	15	3	21	M4x10
AU14	14	16	5	25	2	28	M5x13
AU16	16	18	5	25	2	28	M5x13

Dimensioni entrate / Input dimensions / Antriebsabmessungen

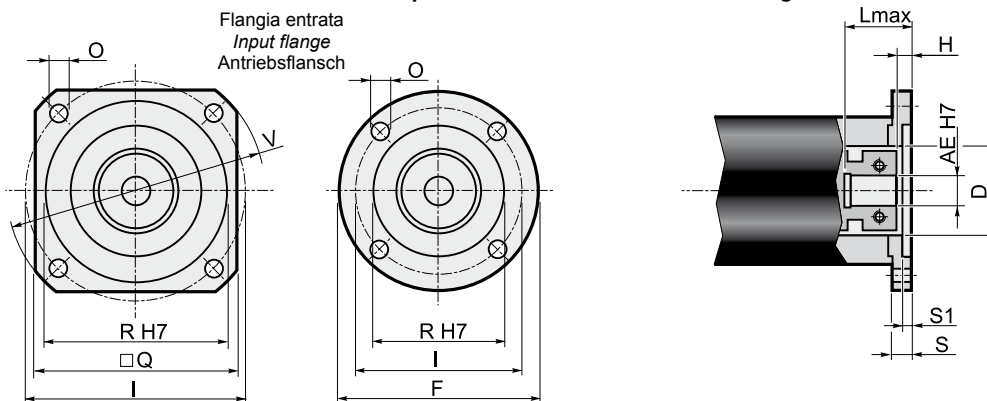

Flange entrata / Input flange / Antriebsflansch										Albero entrata / Input shaft / Antriebswelle																	
										AE																	
										6		6.35		7		8		9		9.52		11		12		12.7	
F	Q	V	I	R (H7)	O	S	S1	D	L _{max}	H	L _{max}	H	L _{max}	H	L _{max}	H	L _{max}	H	L _{max}	H	L _{max}	H	L _{max}	H	L _{max}	H	
P01*	60	=	=	43.82	22	4.5	10	3	22	37	6.5	37	6.5	37	6.5	28	8.5	28	8.5	37	8.5	28	8.5	37	8.5	37	8.5
P02*	=	60	80	66.67	38.1	5.5	10	3	32	37	6.5	37	6.5	37	6.5	28	8.5	28	8.5	37	8.5	28	8.5	37	8.5	37	8.5
P03*	=	60	80	63	40	5.5	10	3.5	32	37	6.5	37	6.5	37	6.5	28	8.5	28	8.5	37	8.5	28	8.5	37	8.5	37	8.5
P04	=	70	90	75	60	6.5	10.5	3.5	32	37.5	7	37.5	7	37.5	7	28.5	9	28.5	9	37.5	9	28.5	9	37.5	9	37.5	9
P05	105	=	=	85	70	6.5	10.5	3.5	32	37.5	7	37.5	7	37.5	7	28.5	9	28.5	9	37.5	9	28.5	9	37.5	9	37.5	9
P06	=	80	110	98.42	73.02	6	11	3.5	35	38	7.5	38	7.5	38	7.5	29	9.5	29	9.5	38	9.5	29	9.5	38	9.5	38	9.5
P07	=	95	120	100	80	6.5	11.5	4	32	38.5	8	38.5	8	38.5	8	29.5	10	29.5	10	38.5	10	29.5	10	38.5	10	38.5	10
P08	=	98	130	115	95	9	11.5	4	32	38.5	8	38.5	8	38.5	8	29.5	10	29.5	10	38.5	10	29.5	10	38.5	10	38.5	10
P09	=	116	160	130	110	9	12	4.5	32	39	8.5	39	8.5	39	8.5	30	10.5	30	10.5	39	10.5	30	10.5	39	10.5	39	10.5
P10*	60	=	=	39	26	4.5	10	3	26	37	6.5	37	6.5	37	6.5	28	8.5	28	8.5	37	8.5	28	8.5	37	8.5	37	8.5
P11*	60	=	=	42	32	4.5	10	3	32	37	6.5	37	6.5	37	6.5	28	8.5	28	8.5	37	8.5	28	8.5	37	8.5	37	8.5
P12*	65	=	=	46	32	4.5	10	3.5	32	37	6.5	37	6.5	37	6.5	28	8.5	28	8.5	37	8.5	28	8.5	37	8.5	37	8.5
P13*	80	=	=	65	50	5.5	10	3.5	32	37	6.5	37	6.5	37	6.5	28	8.5	28	8.5	37	8.5	28	8.5	37	8.5	37	8.5
P14*	60	=	=	39	20	4.5	10	2.5	20	37	6.5	37	6.5	37	6.5	28	8.5	28	8.5	37	8.5	28	8.5	37	8.5	37	8.5
P15	=	75	100	90	60	5.8	12	3.5	32	39	8.5	39	8.5	39	8.5	30	10.5	30	10.5	39	10.5	30	10.5	39	10.5	39	10.5
P16*	60	=	=	45	30	3.5	14	7	30	41	10.5	41	10.5	41	10.5	32	12.5	32	12.5	41	12.5	32	12.5	41	12.5	41	12.5
P17	=	60	82	70	50	4.5	16.5	8	32	43.5	13	43.5	13	43.5	13	34.5	15	34.5	15	43.5	15	34.5	15	43.5	15	43.5	15
P18	=	60	80	60	50	M4	10.5	3.5	32	37.5	7	37.5	7	37.5	7	28.5	9	28.5	9	37.5	9	28.5	9	37.5	9	37.5	9
P19*	60	=	=	36	25	4.5	10	3	25	37	6.5	37	6.5	37	6.5	28	8.5	28	8.5	37	8.5	28	8.5	37	8.5	37	8.5
P20	=	60	82	70	50	5.5	10.5	3.5	32	37.5	7	37.5	7	37.5	7	28.5	9	28.5	9	37.5	9	28.5	9	37.5	9	37.5	9
P21*	60	=	=	46	30	4.5	10	3	30	37	6.5	37	6.5	37	6.5	28	8.5	28	8.5	37	8.5	28	8.5	37	8.5	37	8.5
P22	=	60	80	70.71	36	4.5	10	2	32	37	6.5	37	6.5	37	6.5	28	8.5	28	8.5	37	8.5	28	8.5	37	8.5	37	8.5
P23	=	62	85	70	50	5.5	15.5	3.5	32	42.5	12	42.5	12	42.5	12	33.5	14	33.5	14	42.5	14	33.5	14	42.5	14	42.5	14
P24	=	75	100	90	70	5.8	12	3.5	32	39	8.5	39	8.5	39	8.5	30	10.5	30	10.5	39	10.5	30	10.5	39	10.5	39	10.5
P25	=	70	95	85	55	5.8	12	3.5	32	39	8.5	39	8.5	39	8.5	30	10.5	30	10.5	39	10.5	30	10.5	39	10.5	39	10.5
P26*	=	60	80	65.5	34	5.5	10	3.5	33	37	6.5	37	6.5	37	6.5	28	8.5	28	8.5	37	8.5	28	8.5	37	8.5	37	8.5
P27	=	80	110	95	50	6.5	12	3.5	32	39	8.5	39	8.5	39	8.5	30	10.5	30	10.5	39	10.5	30	10.5	39	10.5	39	10.5
P28	=	60	80	66.67	38.1	M4	9	2.5	32	36	5.5	36	5.5	36	5.5	27	7.5	27	7.5	36	7.5	27	7.5	36	7.5	36	7.5
P29	60	=	=	45	30	M3	11	4	32	38	7.5	38	7.5	38	7.5	29	9.5	29	9.5	38	9.5	29	9.5	38	9.5	38	9.5
P30	=	70	95	85	60	5.8	12	3.5	32	39	8.5	39	8.5	39	8.5	30	10.5	30	10.5	39	10.5	30	10.5	39	10.5	39	10.5
P31	=	62	85	70	50	M4	11	3.5	32	38	7.5	38	7.5	38	7.5	29	9.5	29	9.5	38	9.5	29	9.5	38	9.5	38	9.5
P32	=	60	80	65	40	M5	10	3.5	32	37	6.5	37	6.5	37	6.5	28	8.5	28	8.5	37	8.5	28	8.5	37	8.5	37	8.5
P33	=	85	115	99	60	5.5	11	3.5	32	38	7.5	38	7.5	38	7.5	29	9.5	29	9.5	38	9.5	29	9.5	38	9.5	38	9.5
P34	=	65	87	73.54	40	M4	10	3.5	32	37	6.5	37	6.5	37	6.5	28	8.5	28	8.5	37	8.5	28	8.5	37	8.5	37	8.5
P35	=	60	80	70.71	36	M4	14	2	32	41	10.5	41	10.5	41	10.5	32	12.5	32	12.5	41	12.5	32	12.5	41	12.5	41	12.5
P36	=	85	115	98.42	73.02	6	15	3.5	35	42	11.5	42	11.5	42	11.5	33	13.5	33	13.5	42	13.5	33	13.5	42	13.5	42	13.5
P37	=	95	120	100	80	6.5	16.5	5	32	43.5	13	43.5	13	43.5	13	34.5	15	34.5	15	43.5	15	34.5	15	43.5	15	43.5	15
P38	60	=	=	48	30	M3	11	7	32	38	7.5	38	7.5	38	7.5	29	9.5	29	9.5	38	9.5	29	9.5	38	9.5	38	9.5
P41*	68	=	=	50	30	5.5	10	10	30	34	3.5	34	3.5	34	3.5	25	5.5	25	5.5	34	5.5	25	5.5	34	5.5	34	5.5

* Per assemblare il motore è necessario smontare la flangia dal riduttore (vedere schema di montaggio 2 a pag. 25).

* Before the mounting of the motor it is necessary to remove the flange from the gearbox (see structural arrangement 2 at the top of the page 25).

* Vor dem Einbauen des Motors soll die Getriebeflang abmontiert werden (siehe Bauanleitung 2 auf Seite 25).

Stadi Steps Stufenzahl	1				2								3								
i	3	4	5	6	9	12	16	20	24	30	36	27	36	48	64	80	100	120	144	180	216
n _{1 nom}	4000				4500								5000								
n _{1 max}	6000																				
T _{2N}	90	110	90	75	100	115	115	115	115	85	75	100	120	120	120	120	120	120	120	95	80
T _{2A}	145	170	130	120	160	180	180	180	180	140	130	160	190	190	190	190	190	190	190	150	130
T _{2S}	290	340	260	240	320	360	360	360	360	280	260	320	380	380	380	380	380	380	380	300	260
J	Vedi pag. 14 / See page 14 / Siehe auf Seite 14																				
LpA	< 70																				
R _d	0.96				0.93								0.91								
L _h	20000																				
F _{R2}	2100																				
F _{A2}	1050																				
R _t	11																				
α _{max}	4'				6'								8'								
Kg	2.7				3.5								4.3								

i Rapporto di riduzione nominale
n_{1 nom} Velocità nominale in entrata [min⁻¹]
n_{1 max} Velocità massima in entrata [min⁻¹]
T_{2N} Coppia nominale intermittente in uscita [Nm]
T_{2A} Coppia massima di accelerazione in uscita [Nm]
T_{2S} Coppia massima di emergenza in uscita [Nm]
LpA Livello di rumorosità dB(A) a 3000 min⁻¹
R_d Rendimento dinamico
L_h Durata cuscinetti [h]
F_{R2} Carico radiale nominale in uscita [N] a 300min⁻¹
F_{A2} Carico assiale in uscita [N] a 300min⁻¹
R_t Rigidità torsionale [Nm / arcmin]
α_{max} Gioco angolare massimo [arcmin]
J Momento d'inerzia [kg.cm²]

Nominal ratio
Nominal input speed [min⁻¹]
Maximum input speed [min⁻¹]
Rated intermittent output torque [Nm]
Maximum acceleration output torque [Nm]
Maximum emergency output torque [Nm]
Noise level dB(A) at 3000 min⁻¹
Dynamic efficiency
Bearing life [h]
Rated output radial load [N] at 300min⁻¹
Output axial load [N] at 300min⁻¹
Torsional rigidity [Nm / arcmin]
Maximum backlash [arcmin]
Moment of inertia [kg.cm²]

Nenn-Untersetzungsverhältnis
Nenn-Eingangsdrehzahl [min⁻¹]
Maximale Eingangsdrehzahl [min⁻¹]
Nenn-Abtriebsmoment (im Aussetzbetrieb)[Nm]
Maximales Beschleunigungsmoment am Abtrieb [Nm]
Maximale Überlast am Abtrieb [Nm]
Geräuschpegel dB(A) bei 3000 min⁻¹
Dynamischer Wirkungsgrad
Lebensdauer der Lager [h]
Nenn-Radiallast an der Abtriebswelle bei 300min⁻¹
Axiallast an der Abtriebswelle bei 300min⁻¹
Drehfestigkeit [Nm / arcmin]
Maximale Winkelspiel [arcmin]
Trägheitsmoment [kg.cm²]

1.10 Dimensioni

1.10 Dimensions

1.10 Abmessungen

Dimensioni generali e uscite / General and output dimensions / General-und Abtriebsabmessungen

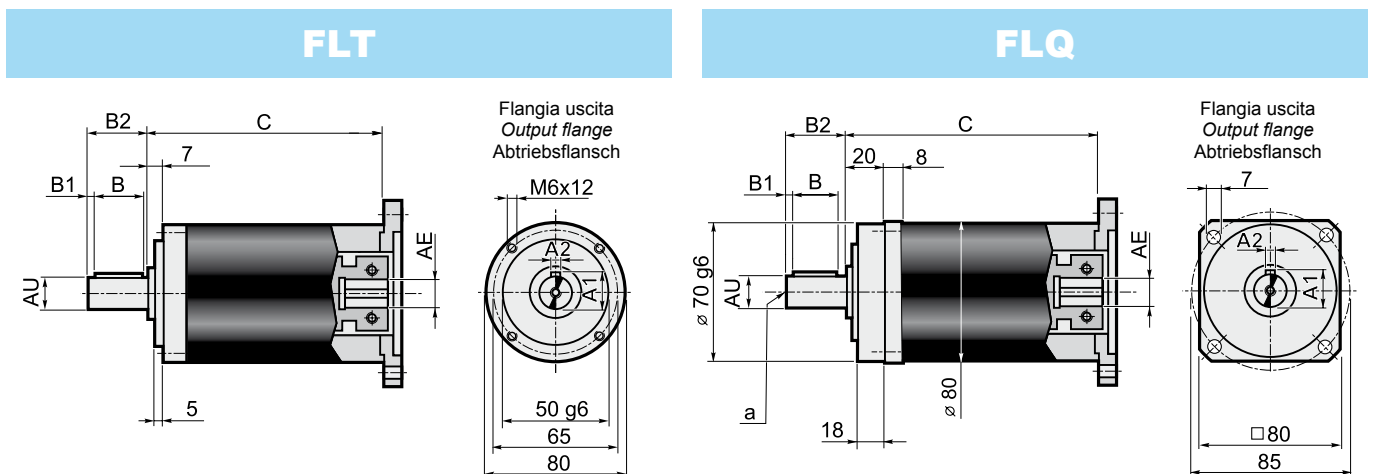

Stadi / Steps / Stufenzahl	1	2	3
C	102	127	152.5
AE= 9-9.52-11-12.7 14-15.87-16-19			

	Albero uscita - Output shaft - Abtriebswelle						
	AU j6	A1	A2	B	B1	B2	a
AU19	19	21.5	6	30	3	36	M6x16
AU22	22	24.5	6	30	3	36	M6x16

Dimensioni entrate / Input dimensions / Antriebsabmessungen

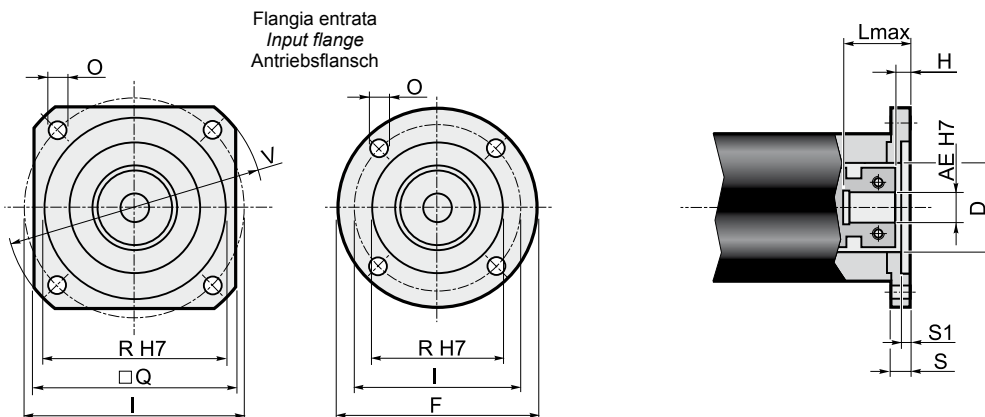

Flange entrata / Input flange / Antriebsflansch										Albero entrata / Input shaft / Antriebswelle																	
										AE																	
										9		9.525		11		12		12.7		14		15.87		16		19	
F	Q	V	I	R (H7)	O	S	S1	D	L _{max}	H	L _{max}	H	L _{max}	H	L _{max}	H	L _{max}	H	L _{max}	H	L _{max}	H	L _{max}	H			
P01*	80	=	=	66.67	38.1	5.5	12	3	38.1	41	3.5	41	6	26	6	41	6	41	6	41	6	41	6	41	6	41	6
P02	=	106.5	140	125.72	55.52	7	11	3	45	40	2.5	40	5	25	5	40	5	40	5	40	5	40	5	40	5	40	5
P03*	=	80	90	75	60	5.5	12	3.5	45	41	3.5	41	6	26	6	41	6	41	6	41	6	41	6	41	6	41	6
P04*	105	=	=	85	70	6.5	12	3.5	45	41	3.5	41	6	26	6	41	6	41	6	41	6	41	6	41	6	41	6
P05	=	82.5	110	98.425	73.02	6.5	12	3	45	41	3.5	41	6	26	6	41	6	41	6	41	6	41	6	41	6	41	6
P06	=	90	120	100	80	6.5	13	4	45	42	4.5	42	7	27	7	42	7	42	7	42	7	42	7	42	7	42	7
P07	=	100	135	115	95	8.5	13	4.5	45	42	4.5	42	7	27	7	42	7	42	7	42	7	42	7	42	7	42	7
P08	=	116	160	130	110	9	13	4.5	45	42	4.5	42	7	27	7	42	7	42	7	42	7	42	7	42	7	42	7
P09*	80	=	=	39	26	4.5	12	4	26	41	3.5	41	6	26	6	41	6	41	6	41	6	41	6	41	6	41	6
P10*	80	=	=	65	50	5.5	12	3.5	45	41	3.5	41	6	26	6	41	6	41	6	41	6	41	6	41	6	41	6
P11	=	150	182	166	115	9	32	11	50x14	61	23.5	61	26	46	26	61	26	61	26	61	26	61	26	61	26	61	26
P12*	=	80	105	90	70	6.5	12	3.5	32	41	3.5	41	6	26	6	41	6	41	6	41	6	41	6	41	6	41	6
P14*	105	=	=	90	70	6	19	9	32	48	10.5	48	13	33	13	48	13	48	13	48	13	48	13	48	13	48	13
P15*	80	=	=	70	50	4.5	17	8	45	46	8.5	46	11	31	11	46	11	46	11	46	11	46	11	46	11	46	11
P16	=	142	190	165	130	11	13	4.5	45	42	4.5	42	7	27	7	42	7	42	7	42	7	42	7	42	7	42	7
P17*	80	=	=	63	40	5.5	12	3.5	40	41	3.5	41	6	26	6	41	6	41	6	41	6	41	6	41	6	41	6
P18	=	130	170	145	110	M8	31	7	32	60	22.5	60	25	45	25	60	25	60	25	60	25	60	25	60	25	60	25
P19*	=	80	105	90	60	6.5	12	3.5	32	41	3.5	41	6	26	6	41	6	41	6	41	6	41	6	41	6	41	6
P20*	=	80	105	85	55	5.5	12	3.5	36	41	3.5	41	6	26	6	41	6	41	6	41	6	41	6	41	6	41	6
P21	=	80	110	95	50	M6	12	3.5	45	41	3.5	41	6	26	6	41	6	41	6	41	6	41	6	41	6	41	6
P22	80	=	=	70	50	M4	12	4	45	41	3.5	41	6	26	6	41	6	41	6	41	6	41	6	41	6	41	6
P23	=	80	90	75	60	M5	12	3.5	45	41	3.5	41	6	26	6	41	6	41	6	41	6	41	6	41	6	41	6
P24	80	=	=	46	30	M4	12	4	30	41	3.5	41	6	26	6	41	6	41	6	41	6	41	6	41	6	41	6
P26	80	=	=	65	40	M5	12	3.5	40	41	3.5	41	6	26	6	41	6	41	6	41	6	41	6	41	6	41	3.5
P27	=	80	110	82.02	36.8	M6	14	10	36.8	43	5.5	43	8	28	8	43	8	43	8	43	8	43	8	43	8	43	5.5
P28	=	90	120	100	80	6.5	28	4	45	57	19.5	57	22	42	22	57	22	57	22	57	22	57	22	57	22	57	22
P29*	80	=	=	66.67	50	5.5	12	3	45	41	3.5	41	6	26	6	41	6	41	6	41	6	41	6	41	6	41	6
P30	=	115	155	130	80	9	13	4	45	42	4.5	42	7	27	7	42	7	42	7	42	7	42	7	42	7	42	7
P31*	=	80	105	56	44	M6	14	10	36.8	43	5.5	43	8	28	8	43	8	43	8	43	8	43	8	43	8	43	8
P32	=	80	105	90	70	M6	12	3.5	32	41	3.5	41	6	26	6	41	6	41	6	41	6	41	6	41	6	41	6
P33	=	130	165	145	110	9	13	4.5	45	42	4.5	42	7	27	7	42	7	42	7	42	7	42	7	42	7	42	7
P34	=	90	120	100	80	M6	19	5	45	48	10.5	48	13	33	13	48	13	48	13	48	13	48	13	48	13	48	13
P36	=	100	135	115	95	M8	25	4.5	45	54	16.5	54	19	39	19	54	19	54	19	54	19	54	19	54	19	54	19
P37	=	85	115	98.99	60	M6	12	3.5	32	41	3.5	41	6	26	6	41	6	41	6	41	6	41	6	41	6	41	6
P38	80	=	=	70	50	M5	12	4	45	41	3.5	41	6	26	6	41	6	41	6	41	6	41	6	41	6	41	6
P39	=	90	120	100	80	6.5	13	4.5	45	42	4.5	42	7	27	7	42	7	42	7	42	7	42	7	42	7	42	7
P40	=	80	90	75	60	M6	12	3.5	45	41	3.5	41	6	26	6	41	6	41	6	41	6	41	6	41	6	41	6

* Per assemblare il motore è necessario smontare la flangia dal riduttore (vedere schema di montaggio 2 a pag. 25).

* Before the mounting of the motor it is necessary to remove the flange from the gearbox (see structural arrangement 2 at the top of the page 25).

* Vor dem Einbauen des Motors soll die Getriebeflangsch abmontiert werden (siehe Bauanleitung 2 auf Seite 25).

Stadi Steps Stufenzahl	1				2								3								
i	3	4	5	7	9	12	16	20	28	35	49	36	48	64	80	100	140	196	245	343	
$n_{1\text{ nom}}$	3000				3500								4000								
$n_{1\text{ max}}$	5000																				
T_{2N}	220	230	200	160	250	260	260	260	260	230	180	280	280	280	280	280	280	280	280	250	200
T_{2A}	350	370	320	300	400	420	420	420	420	370	350	450	450	450	450	450	450	450	450	400	370
T_{2S}	700	750	650	600	800	850	850	850	850	750	700	900	900	900	900	900	900	900	900	800	750
J	Vedi pag. 15 / See page 15 / Siehe auf Seite 15																				
LpA	< 70																				
R _d	0.96				0.93								0.91								
L _h	20000																				
F _{R2}	3700																				
F _{A2}	1850																				
R _t	32																				
$\alpha_{\text{ max}}$	4'				6'								8'								
Kg	7.2				9.3								11.4								

i	Rapporto di riduzione nominale	<i>Nominal ratio</i>	Nenn-Untersetzungsverhältnis
$n_{1\text{ nom}}$	Velocità nominale in entrata [min ⁻¹]	<i>Nominal input speed [min⁻¹]</i>	Nenn-Eingangsrehzahl [min ⁻¹]
$n_{1\text{ max}}$	Velocità massima in entrata [min ⁻¹]	<i>Maximum input speed [min⁻¹]</i>	Maximale Eingangsrehzahl [min ⁻¹]
T_{2N}	Coppia nominale intermittente in uscita [Nm]	<i>Rated intermittent output torque [Nm]</i>	Nenn-Abtriebsmoment (im Aussetzbetrieb)[Nm]
T_{2A}	Coppia massima di accelerazione in uscita [Nm]	<i>Maximum acceleration output torque [Nm]</i>	Maximales Beschleunigungsmoment am Abtrieb [Nm]
T_{2S}	Coppia massima di emergenza in uscita [Nm]	<i>Maximum emergency output torque [Nm]</i>	Maximale Überlast am Abtrieb [Nm]
LpA	Livello di rumorosità dB(A) a 3000 min ⁻¹	<i>Noise level dB(A) at 3000 min⁻¹</i>	Geräuschpegel dB(A) bei 3000 min ⁻¹
R_d	Rendimento dinamico	<i>Dynamic efficiency</i>	Dynamischer Wirkungsgrad
L_h	Durata cuscinetti [h]	<i>Bearing life [h]</i>	Lebensdauer der Lager [h]
F_{R2}	Carico radiale nominale in uscita [N] a 300min ⁻¹	<i>Rated output radial load [N] at 300min⁻¹</i>	Nenn-Radiallast an der Abtriebswelle bei 300min ⁻¹
F_{A2}	Carico assiale in uscita [N] a 300min ⁻¹	<i>Output axial load [N] at 300min⁻¹</i>	Axiallast an der Abtriebswelle bei 300min ⁻¹
R_t	Rigidità torsionale [Nm / arcmin]	<i>Torsional rigidity [Nm / arcmin]</i>	Drehfestigkeit [Nm / arcmin]
$\alpha_{\text{ max}}$	Gioco angolare massimo [arcmin]	<i>Maximum backlash [arcmin]</i>	Maximale Winkelspiel [arcmin]
J	Momento d'inerzia [kg.cm ²]	<i>Moment of inertia [kg.cm²]</i>	Trägheitsmoment [kg.cm ²]

1.10 Dimensioni

1.10 Dimensions

1.10 Abmessungen

Dimensioni generali e uscite / General and output dimensions / General-und Abtriebsabmessungen

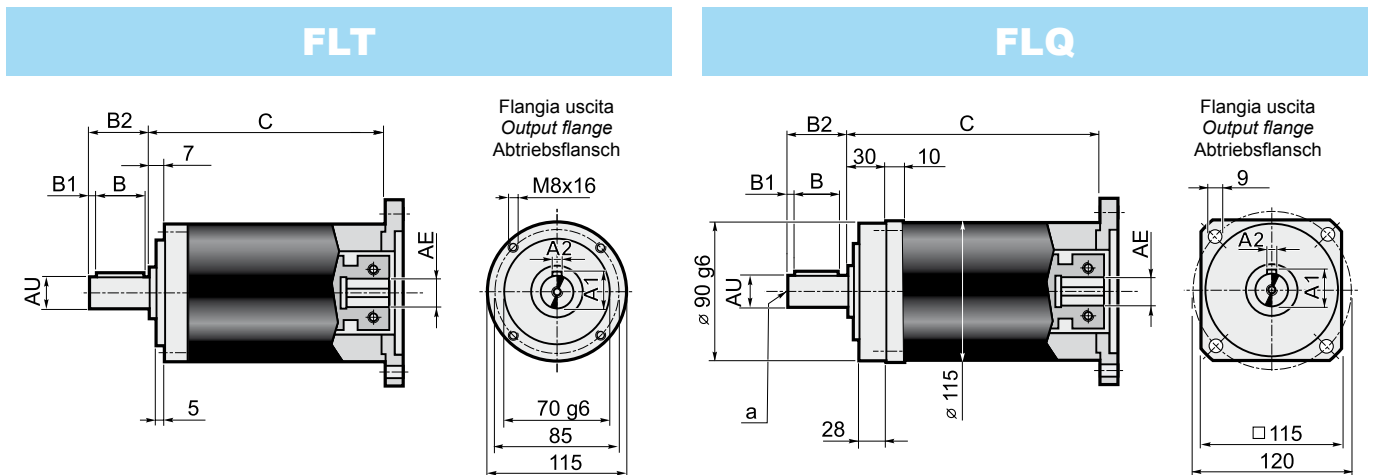

Stadi / Steps / Stufenzahl	1	2	3	
C	126	158.4	191	AE= 12.7-14-15.87-16-19
	145	177	210	AE= 22-24-25-28

	Albero uscita - Output shaft - Abtriebswelle						
	AU j6	A1	A2	B	B1	B2	a
AU25	25	28	8	40	5	50	M8x20
AU32	32	35	10	50	4	58	M10x25

Dimensioni entrate / Input dimensions / Antriebsabmessungen

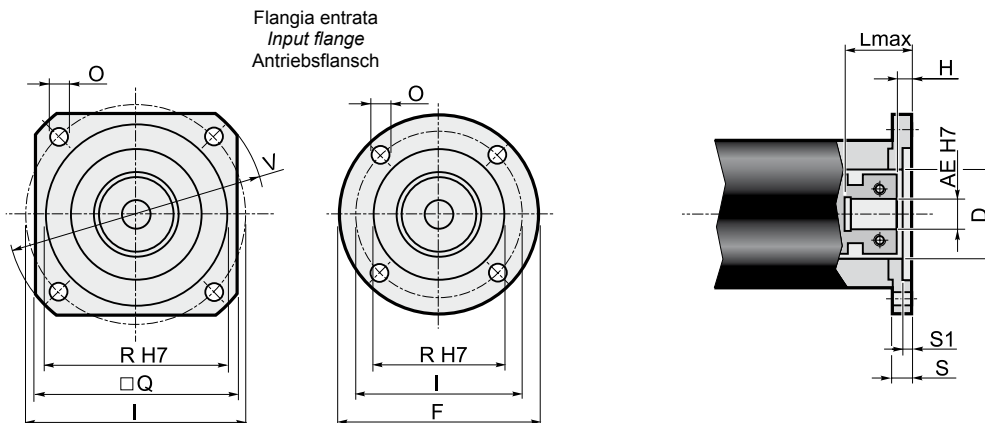

Flange entrata / Input flange / Antriebsflansch		Albero entrata / Input shaft / Antriebswelle																									
		AE																									
		12.7		14		15.87		16		19		22		24		25		28									
F	Q	V	I	R (H7)	O	S	S1	D	L max	H	L max	H	L max	H	L max	H	L max	H	L max	H	L max	H	L max	H			
P01*	=	115	140	125.72	55.52	6.5	13	3	55.52	43	6	35	6	43	6	43	6	43	6	62	6	62	6	62	6	62	6
P02*	115	=	=	75	60	5.5	13	3.5	60	43	6	35	6	43	6	43	6	43	6	62	6	62	6	62	6	62	6
P03*	115	=	=	85	70	6.5	13	3.5	60	43	6	35	6	43	6	43	6	43	6	62	6	62	6	62	6	62	6
P04*	115	=	=	98.42	73.02	6.5	13	3	60	43	6	35	6	43	6	43	6	43	6	62	6	62	6	62	6	62	6
P05*	120	=	=	100	80	6.5	13	4	60	43	6	35	6	43	6	43	6	43	6	62	6	62	6	62	6	62	6
P06*	=	115	140	115	95	9	13	4.5	60	43	6	35	6	43	6	43	6	43	6	62	6	62	6	62	6	62	6
P07	=	115	160	130	110	8.5	13	4.5	60	43	6	35	6	43	6	43	6	43	6	62	6	62	6	62	6	62	6
P08	=	142	190	165	130	11	13	4.5	60	43	6	35	6	43	6	43	6	43	6	62	6	62	6	62	6	62	6
P09	=	192	250	215	180	13	14	4.5	60	44	7	36	7	44	7	44	7	44	7	63	7	63	7	63	7	63	7
P10*	115	=	=	65	50	6.5	13	3.5	50	43	6	35	6	43	6	43	6	43	6	62	6	62	6	62	6	62	6
P11	=	130	170	145	110	M 8	31	7	60	61	24	53	24	61	24	61	24	61	24	80	24	80	24	80	24	80	24
P12	=	130	170	145	110	M 8	17	7	60	47	10	39	10	47	10	47	10	47	10	66	10	66	10	66	10	66	10
P13	=	115	160	130	110	M 8	13	4.5	60	43	6	35	6	43	6	43	6	43	6	62	6	62	6	62	6	62	6
P14*	115	=	=	70	50	6.5	13	3.5	50	43	6	35	6	43	6	43	6	43	6	62	6	62	6	62	6	62	6
P15	115	=	=	90	70	M5	11	3.5	60	41	4	33	4	41	4	41	4	41	4	60	4	60	4	60	4	60	4
P17*	115	=	=	90	70	6.5	13	3.5	60	43	6	35	6	43	6	43	6	43	6	62	6	62	6	62	6	62	6
P18	=	115	155	130	95	8.5	13	4.5	60	43	6	35	6	43	6	43	6	43	6	62	6	62	6	62	6	62	6
P19*	115	=	=	95	50	6.5	13	3.5	50	43	6	35	6	43	6	43	6	43	6	62	6	62	6	62	6	62	6
P20	115	=	=	99	60	M6	13	4	60	43	6	35	6	43	6	43	6	43	6	62	6	62	6	62	6	62	6
P21*	130	=	=	106	82.5	12.5	26.5	15	60	56.5	19.5	48.5	17.5	56.5	19.5	56.5	19.5	56.5	19.5	75.5	19.5	75.5	19.5	75.5	19.5	75.5	19.5
P22	=	144	190	165	110	11	15	4.5	60	45	8	37	8	45	8	45	8	45	8	64	8	64	8	64	8	64	8
P23*	115	=	=	63	40	5.5	11	3.5	40	41	4	33	4	41	4	41	4	41	4	60	4	60	4	60	4	60	4
P24	120	=	=	100	80	M6	18	7	60	48	11	40	11	48	11	48	11	48	11	67	11	67	11	67	11	67	11
P25	=	115	155	115	95	M8	27	4.5	60	57	20	49	20	57	20	57	20	57	20	76	20	76	20	76	20	76	20
P26	=	115	155	131.95	55.52	M8	27	4.5	60	57	20	49	20	57	20	57	20	57	20	76	20	76	20	76	20	76	20

* Per assemblare il motore è necessario smontare la flangia dal riduttore (vedere schema di montaggio 2 a pag. 25).

* Before the mounting of the motor it is necessary to remove the flange from the gearbox (see structural arrangement 2 at the top of the page 25).

* Vor dem Einbauen des Motors soll die Getriebeflang abmontiert werden (siehe Bauanleitung 2 auf Seite 25).

Stadi Steps Stufenzahl	1				2								3								
i	3	4	5	7	9	12	16	20	28	35	49	36	48	64	80	100	140	196	245	343	
n_{1 nom}	3000				3500								4000								
n_{1 max}	5000																				
T_{2N}	430	470	410	340	500	560	560	560	560	470	370	600	600	600	600	600	600	600	500	450	
T_{2A}	700	750	650	600	800	900	900	900	900	750	700	950	950	950	950	950	950	950	800	750	
T_{2S}	1400	1500	1300	1200	1600	1800	1800	1800	1800	1500	1400	1900	1900	1900	1900	1900	1900	1900	1600	1500	
J	Vedi pag. 15 / See page 15 / Siehe auf Seite 15																				
LpA	< 70																				
R_d	0.96				0.93								0.91								
L_h	20000																				
F_{R2}	6600																				
F_{A2}	3300																				
R_t	60																				
α_{max}	4'				6'								8'								
Kg	13.0				17.0								21								

i	Rapporto di riduzione nominale	<i>Nominal ratio</i>	Nenn-Untersetzungsverhältnis
n_{1 nom}	Velocità nominale in entrata [min ⁻¹]	<i>Nominal input speed [min⁻¹]</i>	Nenn-Eingangsrehzahl [min ⁻¹]
n_{1 max}	Velocità massima in entrata [min ⁻¹]	<i>Maximum input speed [min⁻¹]</i>	Maximale Eingangsrehzahl [min ⁻¹]
T_{2N}	Coppia nominale intermittente in uscita [Nm]	<i>Rated intermittent output torque [Nm]</i>	Nenn-Abtriebsmoment (im Aussetzbetrieb)[Nm]
T_{2A}	Coppia massima di accelerazione in uscita [Nm]	<i>Maximum acceleration output torque [Nm]</i>	Maximales Beschleunigungsmoment am Abtrieb [Nm]
T_{2S}	Coppia massima di emergenza in uscita [Nm]	<i>Maximum emergency output torque [Nm]</i>	Maximale Überlast am Abtrieb [Nm]
LpA	Livello di rumorosità dB(A) a 3000 min ⁻¹	<i>Noise level dB(A) at 3000 min⁻¹</i>	Geräuschpegel dB(A) bei 3000 min ⁻¹
R_d	Rendimento dinamico	<i>Dynamic efficiency</i>	Dynamischer Wirkungsgrad
L_h	Durata cuscinetti [h]	<i>Bearing life [h]</i>	Lebensdauer der Lager [h]
F_{R2}	Carico radiale nominale in uscita [N] a 300min ⁻¹	<i>Rated output radial load [N] at 300min⁻¹</i>	Nenn-Radiallast an der Abtriebswelle bei 300min ⁻¹
F_{A2}	Carico assiale in uscita [N] a 300min ⁻¹	<i>Output axial load [N] at 300min⁻¹</i>	Axiallast an der Abtriebswelle bei 300min ⁻¹
R_t	Rigidità torsionale [Nm / arcmin]	<i>Torsional rigidity [Nm / arcmin]</i>	Drehfestigkeit [Nm / arcmin]
α_{max}	Gioco angolare massimo [arcmin]	<i>Maximum backlash [arcmin]</i>	Maximale Winkelspiel [arcmin]
J	Momento d'inerzia [kg.cm ²]	<i>Moment of inertia [kg.cm²]</i>	Trägheitsmoment [kg.cm ²]

1.10 Dimensioni

1.10 Dimensions

1.10 Abmessungen

Dimensioni generali e uscite / General and output dimensions / General-und Abtriebsabmessungen

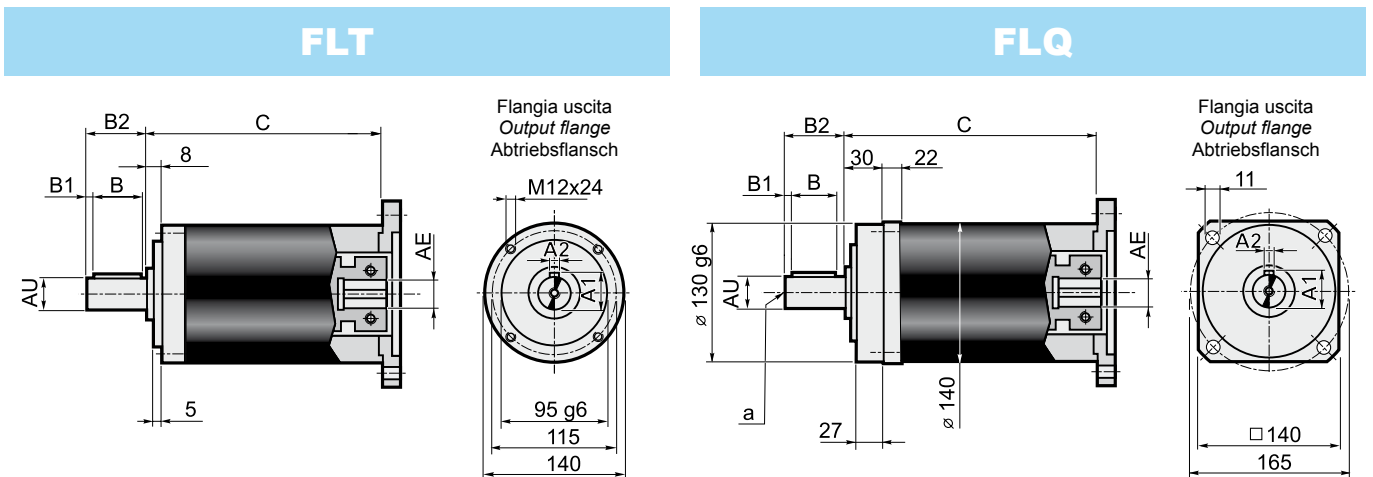

Stadi / Steps / Stufenzahl	1	2	3	
C	160	201	242	AE= 15.87-16-19-22-24
	185	226	267	AE= 28-32-35-38

	Albero uscita - Output shaft - Abtriebswelle						
	AU j6	A1	A2	B	B1	B2	a
AU38	38	41	10	70	5	80	M10x25
AU40	40	43	12	70	5	80	M10x25

Dimensioni entrate / Input dimensions / Antriebsabmessungen

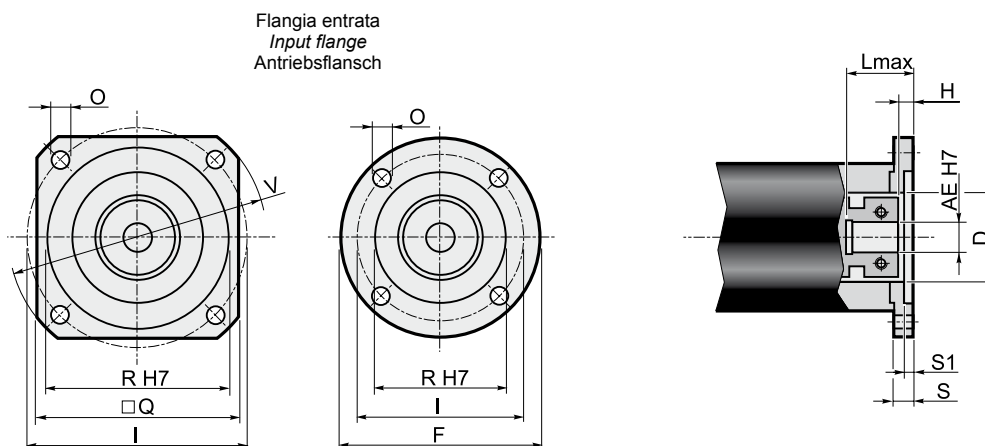

Flange entrata / Input flange / Antriebsflansch										Albero entrata / Input shaft / Antriebswelle																	
										AE																	
										15.87		16		19		22		24		28		32		35		38	
F	Q	V	I	R (H7)	O	S	S1	D	L _{max}	H	L _{max}	H	L _{max}	H	L _{max}	H	L _{max}	H	L _{max}	H	L _{max}	H	L _{max}	H			
P01*	140	=	=	125.72	55.52	6.5	15	4	55.52	57.8	6.8	57.8	6.8	42.8	6.8	57.8	6.8	57.8	6.8	82.8	7.3	82.8	7.3	82.8	7.3	82.8	7.3
P02*	140	=	=	100	80	6.5	15	4	70	57.8	6.8	57.8	6.8	42.8	6.8	57.8	6.8	57.8	6.8	82.8	7.3	82.8	7.3	82.8	7.3	82.8	7.3
P03*	140	=	=	115	95	8.5	15	4.5	70	57.8	6.8	57.8	6.8	42.8	6.8	57.8	6.8	57.8	6.8	82.8	7.3	82.8	7.3	82.8	7.3	82.8	7.3
P04*	=	140	160	130	110	8.5	15	4.5	70	57.8	6.8	57.8	6.8	42.8	6.8	57.8	6.8	57.8	6.8	82.8	7.3	82.8	7.3	82.8	7.3	82.8	7.3
P05	=	142	190	165	130	11	15	4.5	70	57.8	6.8	57.8	6.8	42.8	6.8	57.8	6.8	57.8	6.8	82.8	7.3	82.8	7.3	82.8	7.3	82.8	7.3
P06	=	190	250	215	180	13	15	4.5	70	57.8	6.8	57.8	6.8	42.8	6.8	57.8	6.8	57.8	6.8	82.8	7.3	82.8	7.3	82.8	7.3	82.8	7.3
P07	=	250	300	265	230	13	15	4.5	70	57.8	6.8	57.8	6.8	42.8	6.8	57.8	6.8	57.8	6.8	82.8	7.3	82.8	7.3	82.8	7.3	82.8	7.3
P08	=	130	165	145	110	M 8	18	7	70	60.8	9.8	60.8	9.8	45.8	9.8	60.8	9.8	60.8	9.8	85.8	10.3	85.8	10.3	85.8	10.3	85.8	10.3
P09	=	180	230	200	114.3	13.5	22	11	70	64.8	13.8	64.8	13.8	49.8	13.8	64.8	13.8	64.8	13.8	89.8	14.3	89.8	14.3	89.8	14.3	89.8	14.3
P10	=	115	150	130	95	M 8	15	4.5	70	57.8	6.8	57.8	6.8	42.8	6.8	57.8	6.8	57.8	6.8	82.8	7.3	82.8	7.3	82.8	7.3	82.8	7.3
P11	=	180	230	198	155	13.5	22	7	120x11	64.8	13.8	64.8	13.8	49.8	13.8	64.8	13.8	64.8	13.8	89.8	14.3	89.8	14.3	89.8	14.3	89.8	14.3
P12	=	220	270	235	200	13.5	15	5	70	57.8	6.8	57.8	6.8	42.8	6.8	57.8	6.8	57.8	6.8	82.8	7.3	82.8	7.3	82.8	7.3	82.8	7.3
P13	=	190	250	215	130	13	15	4.5	70	57.8	6.8	57.8	6.8	42.8	6.8	57.8	6.8	57.8	6.8	82.8	7.3	82.8	7.3	82.8	7.3	82.8	7.3
P14	=	142	190	165	110	11	15	4.5	70	57.8	6.8	57.8	6.8	42.8	6.8	57.8	6.8	57.8	6.8	82.8	7.3	82.8	7.3	82.8	7.3	82.8	7.3
P15*	150	=	=	90	70	6.5	15	4	70	57.8	6.8	57.8	6.8	42.8	6.8	57.8	6.8	57.8	6.8	82.8	7.3	82.8	7.3	82.8	7.3	82.8	7.3
P16	=	146	200	177.8	114.3	10.5	15	3.5	70	57.8	6.8	57.8	6.8	42.8	6.8	57.8	6.8	57.8	6.8	82.8	7.3	82.8	7.3	82.8	7.3	82.8	7.3
P17	=	130	165	145	110	M 8	28	7	70	-	-	-	-	70.8	19.8	-	-	-	-	-	-	-	-	-	-	-	
P18	140	=	=	100	80	M 6	22	6	70	64.8	13.8	64.8	13.8	49.8	13.8	64.8	13.8	64.8	13.8	89.8	14.3	89.8	14.3	89.8	14.3	89.8	14.3

* Per assemblare il motore è necessario smontare la flangia dal riduttore (vedere schema di montaggio 2 a pag. 25).

* Before the mounting of the motor it is necessary to remove the flange from the gearbox (see structural arrangement 2 at the top of the page 25)

* Vor dem Einbauen des Motors soll die Getriebeflangsch abmontiert werden (siehe Bauanleitung 2 auf Seite 25).

1 Schema di montaggio / Assembly drawing / Bauanleitung 1

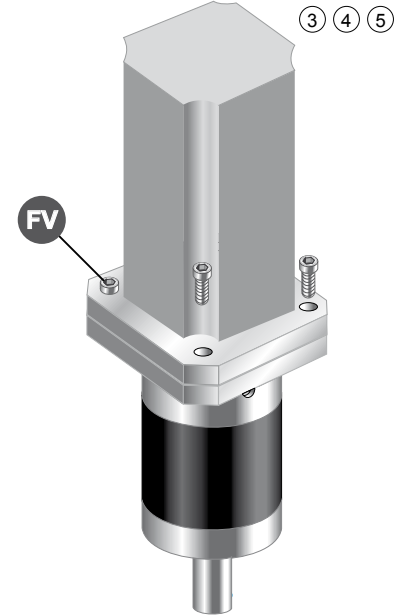
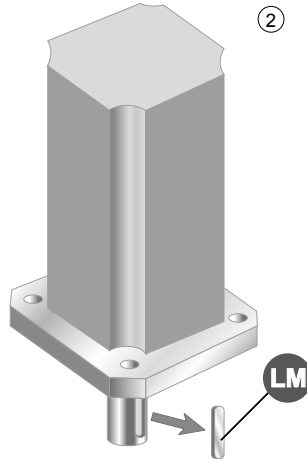
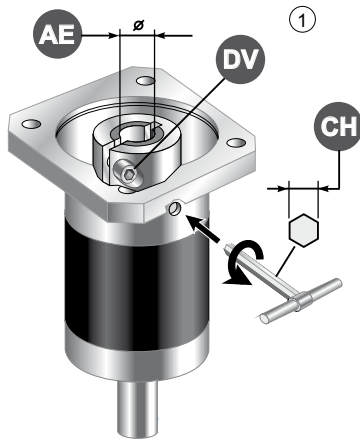

- 1 - Allentare la vite di serraggio del morsetto (DV)
- 2 - Estrarre la linguetta (LM) dall'albero motore
- 3 - Pulire le superfici di contatto delle flange motore e riduttore
- 4 - Calettare il motore sul riduttore evitando urti
- 5 - Stringere le viti di assemblaggio (FV) in modo alternato
- 6 - Assicurarsi che il morsetto venga serrato posizionandolo verso il motore e rispettando la fasatura dei tagli
- 7 - Serrare la vite (o le viti) del morsetto (DV) alla coppia (CS) indicata in tabella

- 1 - Unloose the fastening screw (or screws) of the clamp (DV)
- 2 - Remove the key (LM) from motor shaft
- 3 - Clean the contact surfaces of motor flange/gearbox flange
- 4 - Avoid impacts while fitting motor to gearbox
- 5 - Tighten the assembling screws (FV) alternately
- 6 - Fix the clamp towards the motor and tighten it in compliance with the cuts timing
- 7 - Tighten the clamp screw, or screws (DV) according to the torque (CS) reported in the table

- 1 - die Befestigungsschraube der Klammer (DV) lockern
- 2 - die Feder (LM) aus Motorwelle ziehen
- 3 - die Motorflansch / Getriebeflansch Kontaktfläche reinigen
- 4 - Motor und Getriebe ohne Stöße verkeilen
- 5 - die Befestigungsschrauben (FV) abwechselnd anziehen
- 6 - Die Klammer soll zum Motor angezogen. Dabei soll die Zuendeinstellung der Schnitte geachtet
- 7 - die Schraube (oder Schrauben) der Klammer (DV) zu dem in der Tabelle angegebenen Anzugsmoment anziehen

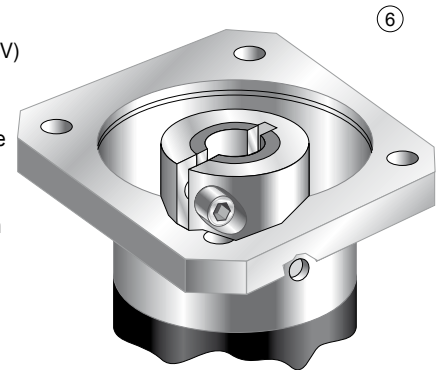

REP 075	AE	6	6.35	7	8	9	9.52	11	12	12.7	14	
	DV	M4 x 16										
	NV	1										
	CH	3										
	CS [Nm]	4.8										
REP 100	AE	9	9.52	11	12	12.7	14	15.87	16	19		
	DV	M4 x 16						M5 x 20				
	NV	1						1				
	CH	3						4				
	CS [Nm]	4.8						9.4				
REP 125	AE	12.7	14	15.87	16	19	22	24	25	28		
	DV	M4 x 16		M5 x 20			M6 x 20					
	NV	1		1			2					
	CH	3		4			5					
	CS [Nm]	4.8		9.4			16.2					
REP 150	AE	15.87	16	19	22	24	28	32	35	38		
	DV	M6 x 20			M6 x 20			M6 x 20				
	NV	1			2			3				
	CH	5			5			5				
	CS [Nm]	16.2			16.2			16.2				

Tutte le viti hanno classe di resistenza 12.9
 All screws supplied according to strenght class 12.9
 Alle Schrauben nach Festigkeitsklasse 12.9 geliefert

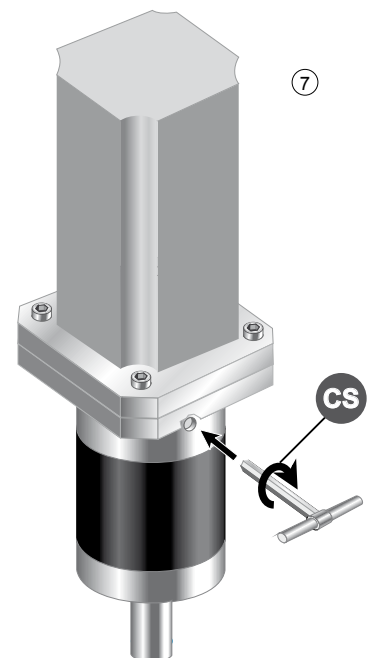

AE= Albero entrata / Input shaft / Antriebswelle
 DV= Diametro vite / Screw diameter / Schraubendurchmesser

NV= Numero viti / Number of screw / Schraubenanzahl
 CS= Coppia di serraggio / Setting torque / Spannungsmoment

2

Schema di montaggio / Assembly drawing / Bauanleitung 2

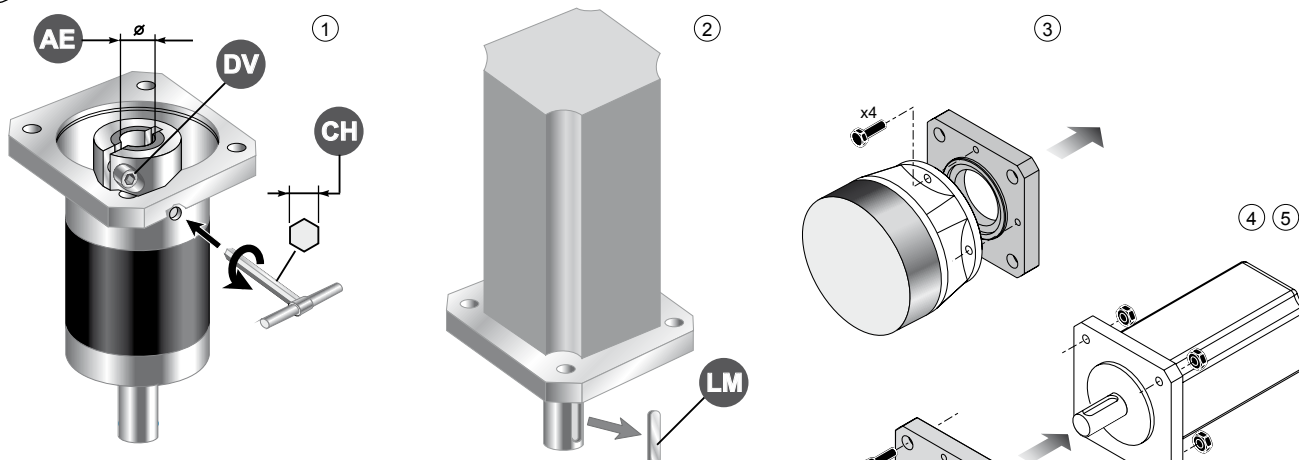

- 1 - Allentare la vite di serraggio del morsetto (DV)
- 2 - Estrarre la linguetta (LM) dall'albero motore
- 3 - Smontare la flangia dal riduttore
- 4 - Pulire le superfici di contatto delle flange motore e riduttore
- 5 - Fissare la flangia sul motore
- 6 - Calettare il motore sul riduttore evitando urti
- 7 - Stringere le viti di assemblaggio (FV) in modo alternato
- 8 - Assicurarsi che il morsetto venga serrato posizionandolo verso il motore e rispettando la fasatura dei tagli
- 9 - Serrare la vite (o le viti) del morsetto (DV) alla coppia (CS) indicata in tabella

- 1 - Unloose the fastening screw (or screws) of the clamp (DV)
- 2 - Remove the key (LM) from motor shaft
- 3 - Remove the flange from the gearbox
- 4 - Clean the contact surfaces of motor flange/gearbox flange
- 5 - Fix the flange on the motor
- 6 - Avoid impacts while fitting motor to gearbox
- 7 - Tighten the assembling screws (FV) alternatively
- 8 - Fix the clamp towards the motor and tighten it in compliance with the cuts timing
- 9 - Tighten the clamp screw, or screws (DV) according to the torque (CS) reported in the table

- 1 - die Befestigungsschraube der Klammer (DV) lockern
- 2 - die Feder (LM) aus Motorwelle ziehen
- 3 - die Flansch von Getriebe abmontieren
- 4 - die Motorflansch / Getriebe- flansch Kontaktfläche reinigen
- 5 - die Flansch an Motor befestigen
- 6 - Motor und Getriebe ohne Stöße verkeilen
- 7 - die Befestigungsschrauben (FV) abwechselnd anziehen
- 8 - Die Klammer soll zum Motor angezogen. Dabei soll die Zuendeinstellung de Schnitte geachtet
- 9 - die Schraube (oder Schrauben) der Klammer (DV) zu dem in der Tabelle angegebenen Anzugsmoment anziehen

REP 075	AE	6	6.35	7	8	9	9.52	11	12	12.7	14	
	DV	M4 x 16										
	NV	1										
	CH	3										
	CS [Nm]	4.8										
REP 100	AE	9	9.52	11	12	12.7	14	15.87	16	19		
	DV	M4 x 16						M5 x 20				
	NV	1						1				
	CH	3						4				
	CS [Nm]	4.8						9.4				
REP 125	AE	12.7	14	15.87	16	19	22	24	25	28		
	DV	M4 x 16		M5 x 20			M6 x 20					
	NV	1		1			2					
	CH	3		4			5					
	CS [Nm]	4.8		9.4			16.2					
REP 150	AE	15.87	16	19	22	24	28	32	35	38		
	DV	M6 x 20			M6 x 20			M6 x 20				
	NV	1			2			3				
	CH	5			5			5				
	CS [Nm]	16.2			16.2			16.2				

Tutte le viti hanno classe di resistenza 12.9
 All screws supplied according to strenght class 12.9
 Alle Schrauben nach Festigkeitsklasse 12.9 geliefert

AE= Albero entrata / Input shaft / Antriebswelle
 DV= Diametro vite / Screw diameter / Schraubendurchmesser

NV= Numero viti / Number of screw / Schraubenanzahl
 CS= Coppia di serraggio / Setting torque / Spannungsmoment

2.0	RIDUTTORI EPICICLOIDALI SERIE EP	PLANETARY GEARBOXES EP SERIES	PLANETENGETRIEBE SERIE EP	
2.1	Caratteristiche	<i>Characteristics</i>	Merkmale	28
2.2	Designazione	<i>Designation</i>	Bezeichnung	29
2.3	Selezione	<i>Selection</i>	Getriebeauswahl	29
2.4	Gioco angolare	<i>Backlash</i>	Spiel	29
2.5	Carichi radiali e assiali su albero lento	<i>Radial and axial loads on output shaft</i>	Radial-und Axiallasten an der Ausgangswelle	30
2.6	Lubrificazione	<i>Lubrication</i>	Schmierung	30
2.7	Momento d'inerzia	<i>Moment of inertia</i>	Trägheitsmoment	31
2.8	Dati tecnici	<i>Technical data</i>	Technische Daten	34
2.9	Dimensioni	<i>Dimensions</i>	Abmessungen	34
2.10	Istruzioni per il montaggio del motore	<i>Instructions for the motor assem- bling</i>	Anleitung für Motoranbau	44



2.1 Caratteristiche

La serie di riduttori epicicloidali EP è il risultato di un ottimo rapporto tra economicità del prezzo e garanzia di precisione delle caratteristiche di funzionamento. I nostri riduttori sono stati realizzati per un'utilizzazione prevalente sulle seguenti applicazioni:

- Macchine utensili
- Macchine per la lavorazione del legno
- Linee transfer
- Macchine da stampa
- Macchine automatiche per confezionamento ed imballaggio
- Automazioni
- Manipolatori
- Macchine serigrafiche
- Guide lineari

La gamma dei riduttori è costituita da 5 grandezze (55, 75, 90, 120 e 155), a 1 e 2 stadi di riduzione, ognuna con due tipi di alberi uscita (tipo A e tipo T) e flange uscita di tipo A, T e Q.

Corpo: costruito in acciaio, garantisce robustezza e una elevata affidabilità nel tempo.

Flange: le flange in entrata ed in uscita sono costruite in alluminio e sono disponibili in molteplici varianti costruttive.

Alberi: sono costruiti in acciaio legato bonificato.

Ingranaggi: in acciaio legato da cementazione e tempra, con dentature rettificata.

Cuscinetti: di elevata qualità opportunamente dimensionati per garantire elevate durate e silenziosità di funzionamento.

2.1 Characteristics

The planetary gearbox EP series is the result of the outstanding ratio competitive price / precision guaranteed with regard to operating features. Our gearboxes are manufactured for prevailing utilization in the following applications:

- *Machine tools*
- *Woodworking machines*
- *Transfer machines*
- *Printing machines*
- *Automatic packing and packaging machines*
- *Automation*
- *Mechanical hands*
- *Silk-screen process machines*
- *Linear guides*

The EP series is available in 5 sizes (55, 75, 90, 120 and 155), with 1 or 2 reduction stages, with two types of output shaft (A and T) and three types of output flange (A, T and Q).

Housing: *made of special nitrided steel to assure strength, high reliability and long life.*

Flanges: *input and output flanges made of aluminium and available in several versions.*

Shafts: *made of hardened and tempered alloy steel.*

Gears: *made of casehardened and tempered alloy steel, with ground toothing.*

Bearings: *high quality and suitably sized to assure long life and noiseless working.*

2.1 Merkmale

Die EP Serie von Planetengetrieben ist das Ergebnis des hervorragenden Verhältnis guten Preis / garantierte Präzision der Betriebseigenschaften. Unsere Getriebe sind für überwiegende Verwendung in der folgenden Applikationen hergestellt:

- Werkzeugmaschinen
- Holzbearbeitungsmaschinen
- Transfermaschinen
- Druckmaschinen
- Automatische Verpackungsmaschinen
- Automation
- Manipulatoren
- Siebdruckmaschinen
- Linearführungen

Die EP Serie ist in 5 Größen (55, 75, 90, 120 und 155) mit 1 oder 2 Untersetzungsstufen, mit zwei Typen von Abtriebswellen (A und T) und drei Typen von Abtriebsflanschen (A, T und Q) verfügbar.

Gehäuse: aus Spezial-Nitrierstahl. Garantiert Robustheit und dauerhaft hohe Zuverlässigkeit.

Ein- u. Ausgangsflansche: aus Aluminium, in zahlreichen Varianten lieferbar.

Wellen: aus vergütetem Legierungsstahl.

Zahnräder: aus Einsatzstahl mit geschliffenen Zahnflanken.

Lager: sind hochwertig und zweckmäßig bemessen, um eine lange Lebensdauer und einen geräuscharmen Lauf zu garantieren.

2.2 Designazione

2.2 Designation

2.2 Bezeichnung

Riduttore epicicloidale Planetary gearbox Planetengetriebe	Grandezza Size Größe	Numero di stadi Steps Untersetzungsstufen	Coassiale Coaxial Koaxial	Rapporto di riduzione Ratio Untersetzungsverhältnis	Albero uscita Output shaft Durchmesser Abtriebswelle	Flangia uscita Output flange Ausgangsflansch	Albero entrata Input shaft Durchmesser Eingangswelle	Flangia in entrata Input flange Eingangsflansch
EP	55	2	C	100	A	A	AE..	P..
	55 75 90 120 155	1 2	C	3 - 100	A T	A T Q	Vedi tabelle See tables Siehe Tab.	Vedi tabelle See tables Siehe Tab.

2.3 Selezione

Per la selezione dei riduttori epicicloidali EP, seguire la procedura descritta al paragrafo 1.3.

2.3 Selection

Make the selection of the planetary gearboxes EP Series as described at paragraph 1.3

2.3 Getriebeauswahl

Die Wahl der Planetengetriebe Serie EP wird wie im Abschnitt 1.3 ausgeführt.

2.4 Gioco angolare (α_{max})

Gioco massimo [arcmin] misurato sull'albero uscita, con albero entrata bloccato applicando una coppia pari al 2% della coppia nominale.

2.4 Backlash (α_{max})

Max. backlash measured on output shaft by torque equals to 2% of the nominal torque value with input shaft blocked.

2.4 Spiel (α_{max})

Maximales Spiel [arcmin], gemessen an der Abtriebswelle bei blockierter Eingangswelle mit 2% des Nennmoments.

2.5 Carichi radiali e assiali su albero lento

Nella tabella delle prestazioni sono indicati i valori, espressi in N, dei carichi assiali e radiali ammissibili alle diverse velocità per una durata dei cuscinetti di 20.000 ore. Il carico radiale F_{R2} si considera applicato ad una distanza dalla battuta pari alla metà della lunghezza dell'albero lento. Per distanze y diverse, è possibile calcolare il nuovo carico massimo ammissibile F_{R2Y} utilizzando formula e coefficienti indicati nella tabella.

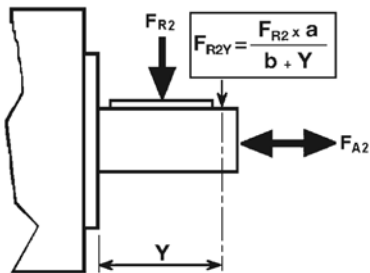

2.5 Radial and axial loads on output shaft

The table of performances shows admissible axial and radial load values expressed in N for different speeds and for a bearing life of 20.000 hours. Radial load F_{R2} calculations have been based on loads applied to the center line of the output shaft extension. For different y distance it is possible to calculate the new maximum admissible load by using formula and coefficient shown in the table.

2.5 Radial-und Axiallasten an der Abtriebswelle

Die Leistungstabelle enthält die in N ausgedrückten Werte der Axial- und Radiallasten für verschiedene Umdrehungszahlen. Diesen Werten liegt eine Lebensdauer der Lager von 20.000 Stunden zugrunde. Die Radiallast F_{R2} greift hierbei auf der Mitte der Abtriebswelle an. Greift die Radiallast an einem anderen Punkt der Abtriebswelle an, so kann man die zulässige Radiallast mit der folgenden Formel sowie den dazugehörigen Koeffizienten berechnen:

	EP 55	EP 75	EP 90	EP 120	EP 155
a	27	46	56	77	95
b	18	32	39	52	64

2.6 Lubrificazione

I riduttori EP sono forniti completi di lubrificante a vita pertanto non necessitano di manutenzione. In fase di ordine specificare la posizione di montaggio.

2.6 Lubrication

EP gearboxes are supplied filled with long-life lubricant and do not require any maintenance. When ordering it is important to specify the exact mounting position.

2.6 Schmierung

Die Planetengetriebe EP werden inklusive Dauerschmierung geliefert und sind wartungsfrei. Bei der Bestellung bitte die Einbauposition angeben.

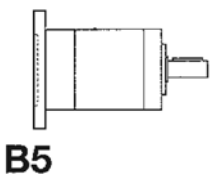

B5

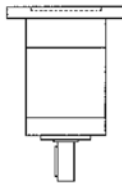

V1

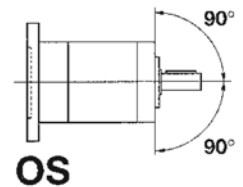
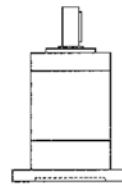

V3

OS

Simbologia e unità di misura

i	Rapporto di riduzione nominale
$n_{1 \text{ nom}}$	Velocità nominale in entrata [min^{-1}]
$n_{1 \text{ max}}$	Velocità massima in entrata [min^{-1}]
T_{2N}	Coppia nominale intermittente in uscita [Nm]
T_{2A}	Coppia massima di accelerazione in uscita [Nm]
T_{2S}	Coppia massima di emergenza in uscita [Nm]
LpA	Livello di rumorosità dB(A) a 3000 min^{-1}
Rd	Rendimento dinamico
L_h	Durata cuscinetti [h]
F_{R2}	Carico radiale nominale in uscita [N] a 100 min^{-1}
F_{A2}	Carico assiale in uscita [N] a 100 min^{-1}
R_t	Rigidità torsionale [Nm / arcmin]
α_{max}	Gioco angolare standard [arcmin]
J_{min}	Momento d'inerzia minimo [$\text{kg} \cdot \text{cm}^2$]
J_{max}	Momento d'inerzia massimo [$\text{kg} \cdot \text{cm}^2$]

Symbols and unit of measure

i	Nominal ratio
$n_{1 \text{ nom}}$	Nominal input speed [min^{-1}]
$n_{1 \text{ max}}$	Maximum input speed [min^{-1}]
T_{2N}	Intermittent output torque [Nm]
T_{2A}	Maximum acceleration output torque [Nm]
T_{2S}	Maximum emergency output torque [Nm]
LpA	Noise level dB(A) at 3000 min^{-1}
Rd	Dynamic efficiency
L_h	Bearing life [h]
F_{R2}	Output radial load [N] at 100 min^{-1}
F_{A2}	Output axial load [N] at 100 min^{-1}
R_t	Torsional stiffness [Nm / arcmin]
α_{max}	Standard backlash [arcmin]
J_{min}	Min. moment of inertia [$\text{kg} \cdot \text{cm}^2$]
J_{max}	Max. moment of inertia [$\text{kg} \cdot \text{cm}^2$]

Abkürzungen und Maßeinheiten

i	Nenn-Untersetzungsverhältnis
$n_{1 \text{ nom}}$	Nenn-Eingangsdrehzahl [min^{-1}]
$n_{1 \text{ max}}$	Maximale Eingangsdrehzahl [min^{-1}]
T_{2N}	Nenn-Abtriebsmoment (im Aussetzbetrieb) [Nm]
T_{2A}	Maximales Beschleunigungsmoment [Nm]
T_{2S}	Maximale Überlast [Nm]
LpA	Geräuschpegel dB(A) bei 3000 min^{-1}
Rd	Dynamischer Wirkungsgrad
L_h	Lebensdauer der Lager [h]
F_{R2}	Nenn-Radiallast an der Abtriebswelle bei 100 min^{-1}
F_{A2}	Axiallast an der Abtriebswelle bei 100 min^{-1}
R_t	Drehfestigkeit [Nm / arcmin]
α_{max}	Standard Spiel [arcmin]
J_{min}	Trägheitsmoment min. [$\text{kg} \cdot \text{cm}^2$]
J_{max}	Trägheitsmoment max. [$\text{kg} \cdot \text{cm}^2$]

2.7 Momento d'inerzia J
[kg·cm²]

2.7 Moment of inertia J
[kg·cm²]

2.7 Trägheitsmoment J
[kg·cm²]

EP 55								
Albero entrata / Input shaft / Antriebswelle								
Stadi Steps Stufenzahl	i	6	6.35	7	8	9	9.525	11
1	3	0.07	0.07	0.07	0.09	0.09	0.09	0.09
	4	0.06	0.06	0.06	0.08	0.08	0.08	0.08
	5	0.06	0.06	0.06	0.07	0.07	0.07	0.08
	7	0.06	0.06	0.06	0.07	0.07	0.07	0.07
	10	0.05	0.05	0.05	0.07	0.07	0.07	0.07
2	9	0.07	0.07	0.07	0.09	0.09	0.09	0.09
	12	0.07	0.07	0.07	0.09	0.09	0.09	0.09
	15	0.07	0.07	0.07	0.09	0.09	0.09	0.09
	16	0.06	0.06	0.06	0.08	0.08	0.08	0.08
	20	0.06	0.06	0.06	0.08	0.08	0.07	0.08
	25	0.06	0.06	0.06	0.07	0.07	0.07	0.08
	28	0.06	0.06	0.06	0.07	0.07	0.07	0.07
	35	0.06	0.06	0.06	0.07	0.07	0.07	0.07
	40	0.05	0.05	0.05	0.07	0.07	0.07	0.07
	50	0.05	0.05	0.05	0.07	0.07	0.07	0.07
	70	0.05	0.05	0.05	0.07	0.07	0.07	0.07
100	0.05	0.05	0.05	0.07	0.07	0.07	0.07	

EP 75											
Albero entrata / Input shaft / Antriebswelle											
Stadi Steps Stufenzahl	i	6	6.35	7	8	9	9.525	11	12	12.7	14
1	3	0.17	0.17	0.17	0.18	0.18	0.18	0.20	0.20	0.20	0.22
	4	0.12	0.12	0.12	0.13	0.13	0.13	0.14	0.15	0.14	0.16
	5	0.11	0.11	0.11	0.12	0.12	0.12	0.13	0.14	0.13	0.15
	7	0.09	0.09	0.09	0.11	0.11	0.11	0.12	0.12	0.12	0.14
	10	0.09	0.09	0.09	0.10	0.10	0.10	0.11	0.12	0.11	0.13
2	9	0.16	0.16	0.16	0.17	0.17	0.17	0.19	0.19	0.19	0.21
	12	0.16	0.16	0.16	0.17	0.17	0.17	0.18	0.18	0.18	0.20
	15	0.15	0.15	0.15	0.17	0.17	0.17	0.18	0.18	0.18	0.20
	16	0.12	0.12	0.12	0.13	0.13	0.13	0.14	0.15	0.14	0.16
	20	0.12	0.12	0.12	0.13	0.13	0.13	0.14	0.14	0.14	0.16
	25	0.10	0.10	0.10	0.12	0.12	0.12	0.13	0.13	0.13	0.15
	28	0.09	0.09	0.09	0.11	0.11	0.11	0.12	0.12	0.12	0.14
	35	0.09	0.09	0.09	0.11	0.11	0.11	0.12	0.12	0.12	0.14
	40	0.09	0.09	0.09	0.10	0.10	0.10	0.11	0.12	0.11	0.13
	50	0.09	0.09	0.09	0.10	0.10	0.10	0.11	0.12	0.11	0.13
	70	0.09	0.09	0.09	0.10	0.10	0.10	0.11	0.12	0.11	0.13
100	0.09	0.09	0.09	0.10	0.10	0.10	0.11	0.12	0.11	0.13	

I valori dei momenti d'inerzia riportati si riferiscono all'albero entrata.

The moment of inertia values refer to the input shaft.

Die Werte der Trägheitsmoment beziehen sich auf die Antriebswelle.

2.7 Momento d'inerzia J
[kg·cm²]

2.7 Moment of inertia J
[kg·cm²]

2.7 Trägheitsmoment J
[kg·cm²]

		EP 90									
		Albero entrata / Input shaft / Antriebswelle									
Stadi Steps Stufenzahl	i	9	9.525	11	12	12.7	14	15.87	16	19	
1	3	0.53	0.53	0.54	0.54	0.54	0.56	0.76	0.76	0.73	
	4	0.35	0.35	0.36	0.36	0.36	0.38	0.58	0.58	0.55	
	5	0.29	0.29	0.30	0.30	0.30	0.32	0.52	0.52	0.49	
	7	0.24	0.24	0.25	0.25	0.25	0.27	0.47	0.47	0.44	
	10	0.21	0.21	0.22	0.23	0.23	0.25	0.44	0.44	0.41	
2	9	0.53	0.53	0.54	0.55	0.55	0.56	0.76	0.76	0.73	
	12	0.51	0.51	0.52	0.53	0.53	0.55	0.74	0.74	0.71	
	15	0.51	0.51	0.52	0.52	0.52	0.54	0.74	0.74	0.70	
	16	0.34	0.34	0.35	0.35	0.35	0.37	0.57	0.57	0.54	
	20	0.34	0.34	0.35	0.35	0.35	0.37	0.57	0.57	0.53	
	25	0.28	0.28	0.29	0.29	0.29	0.31	0.51	0.51	0.48	
	28	0.24	0.23	0.24	0.25	0.25	0.27	0.46	0.46	0.43	
	35	0.23	0.23	0.24	0.25	0.25	0.27	0.46	0.46	0.43	
	40	0.21	0.21	0.22	0.23	0.23	0.24	0.44	0.44	0.41	
	50	0.21	0.21	0.22	0.23	0.22	0.24	0.44	0.44	0.41	
	70	0.21	0.21	0.22	0.23	0.22	0.24	0.44	0.44	0.41	
100	0.21	0.21	0.22	0.23	0.22	0.24	0.44	0.44	0.41		

		EP 120							
		Albero entrata / Input shaft / Antriebswelle							
Stadi Steps Stufenzahl	i	12.7	14	15.87	16	19	22	24	28
1	3	2.02	2.08	2.25	2.25	2.22	4.36	4.32	4.17
	4	1.13	1.19	1.36	1.36	1.33	3.47	3.43	3.28
	5	0.86	0.91	1.08	1.08	1.05	3.19	3.15	3.01
	7	0.62	0.68	0.85	0.85	0.82	2.96	2.92	2.77
	10	0.51	0.56	0.73	0.73	0.70	2.84	2.80	2.66
2	9	2.00	2.06	2.23	2.23	2.20	4.34	4.30	4.15
	12	1.92	1.97	2.14	2.14	2.11	4.26	4.22	4.07
	15	1.88	1.93	2.10	2.10	2.07	4.22	4.18	4.03
	16	1.07	1.13	1.30	1.30	1.27	3.41	3.37	3.22
	20	1.05	1.10	1.28	1.28	1.24	3.39	3.35	3.20
	25	0.80	0.86	1.03	1.03	0.99	3.14	3.10	2.95
	28	0.61	0.66	0.83	0.83	0.80	2.94	2.90	2.76
	35	0.60	0.65	0.82	0.82	0.79	2.94	2.90	2.75
	40	0.50	0.55	0.72	0.72	0.69	2.83	2.79	2.65
	50	0.49	0.55	0.72	0.72	0.68	2.83	2.79	2.64
	70	0.49	0.54	0.71	0.71	0.68	2.83	2.79	2.64
100	0.49	0.54	0.71	0.71	0.68	2.83	2.79	2.64	

I valori dei momenti d'inerzia riportati si riferiscono all'albero entrata.

The moment of inertia values refer to the input shaft.

Die Werte der Trägheitsmoment beziehen sich auf die Antriebswelle.

2.7 **Momento d'inerzia J**
[kg·cm²]

2.7 **Moment of inertia J**
[kg·cm²]

2.7 **Trägheitsmoment J**
[kg·cm²]

		EP 155								
		Albero entrata / <i>Input shaft</i> / Antriebswelle								
Stadi Steps Stufenzahl	i	15.87	16	19	22	24	28	32	35	38
1	3	6.97	6.97	7.01	8.24	8.21	12.21	14.05	13.92	13.59
	4	4.45	4.45	4.48	5.72	5.68	9.69	11.53	11.40	11.07
	5	3.57	3.57	3.60	4.84	4.80	8.80	10.64	10.51	10.19
	7	2.86	2.86	2.89	4.13	4.09	8.09	9.93	9.81	9.48
	10	2.49	2.49	2.52	3.76	3.72	7.73	9.57	9.44	9.11
2	9	6.84	6.84	6.87	8.11	8.07	12.07	13.91	13.79	13.46
	12	6.55	6.55	6.59	7.83	7.79	11.79	13.63	13.51	13.18
	15	6.46	6.46	6.49	7.73	7.69	11.70	13.54	13.41	13.08
	16	4.22	4.22	4.25	5.49	5.45	9.45	11.29	11.17	10.84
	20	4.16	4.16	4.19	5.43	5.40	9.40	11.24	11.11	10.78
	25	3.38	3.38	3.41	4.65	4.62	8.62	10.46	10.33	10.00
	28	2.78	2.78	2.81	4.05	4.02	8.02	9.86	9.73	9.40
	35	2.76	2.76	2.80	4.03	4.00	8.00	9.84	9.71	9.38
	40	2.45	2.45	2.48	3.72	3.69	7.69	9.53	9.40	9.07
	50	2.44	2.44	2.48	3.71	3.68	7.68	9.52	9.39	9.06
	70	2.44	2.44	2.47	3.71	3.67	7.67	9.51	9.39	9.06
100	2.43	2.43	2.46	3.70	3.67	7.67	9.51	9.38	9.05	

I valori dei momenti d'inerzia riportati si riferiscono all'albero entrata.

The moment of inertia values refer to the input shaft.

Die Werte der Trägheitsmoment beziehen sich auf die Antriebswelle.

EP 55																		Stadi Steps Stufenzahl	
Stadi Steps Stufenzahl	1					2												1	2
	i	3	4	5	7	10	9	12	15	16	20	25	28	35	40	50	70		
T _{2N}	12	14	16	12	10	14	16	16	16	16	16	16	16	16	16	14	12	n _{1nom}	4000
T _{2A}	22	24	24	22	20	24	28	28	28	28	28	28	28	28	28	24	22	n _{1max}	5000
T _{2S}	44	48	48	44	40	48	56	56	56	56	56	56	56	56	56	48	44	LpA	< 70
J	Vedi pag. 31 / See page 31 / Siehe auf Seite 31																	Lh	20000
R _t	1.0					0.9					1.0					0.9		F _{R2}	300
R _d	0.96					0.93												F _{A2}	450
Kg	0.8					1.8												α _{max}	8' 10'

2.9 Dimensioni

2.9 Dimensions

2.9 Abmessungen

Dimensioni generali e uscite / General and output dimensions / General-und Abtriebsabmessungen

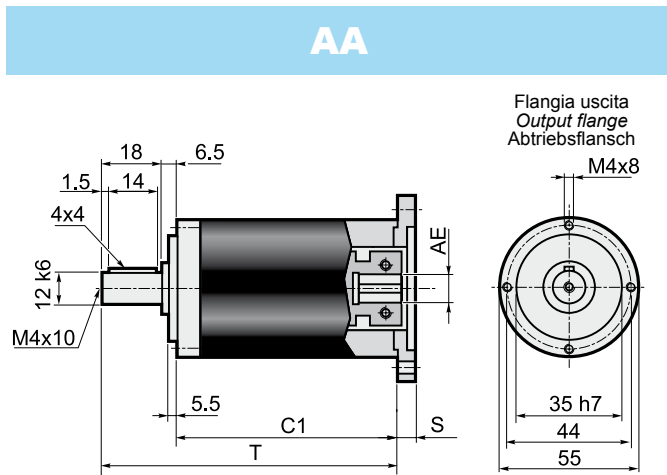

Stadi / Steps / Stufenzahl	1	2	AE= 6 - 6.35 - 7 - 8 - 9 - 9.52 - 11
C1	62.5	81.5	
T	87	106	

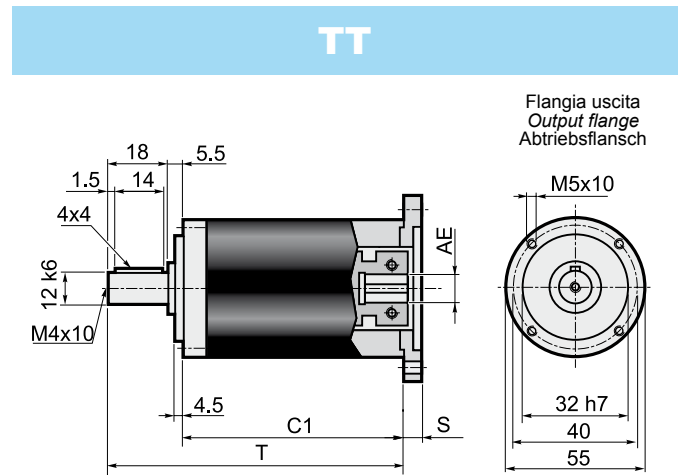

Stadi / Steps / Stufenzahl	1	2	AE= 6 - 6.35 - 7 - 8 - 9 - 9.52 - 11
C1	63.5	82.5	
T	87	106	

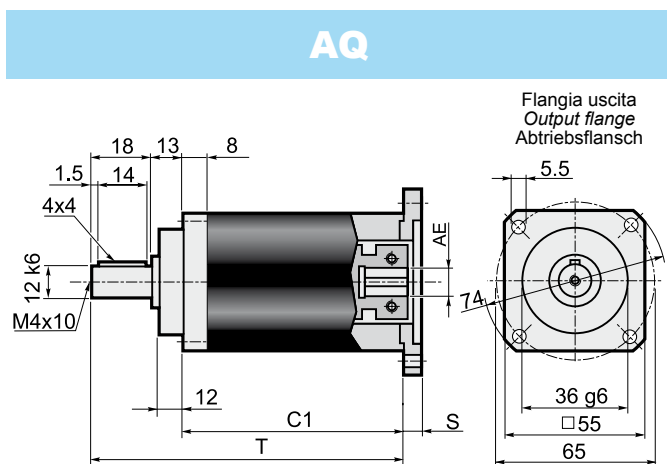

Stadi / Steps / Stufenzahl	1	2	AE= 6 - 6.35 - 7 - 8 - 9 - 9.52 - 11
C1	56	75	
T	87	106	

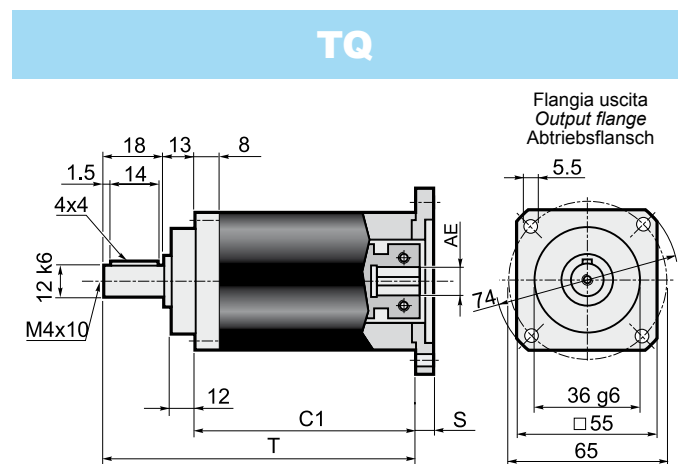

Stadi / Steps / Stufenzahl	1	2	AE= 6 - 6.35 - 7 - 8 - 9 - 9.52 - 11
C1	56	75	
T	87	106	

Dimensioni entrate / Input dimensions / Antriebsabmessungen

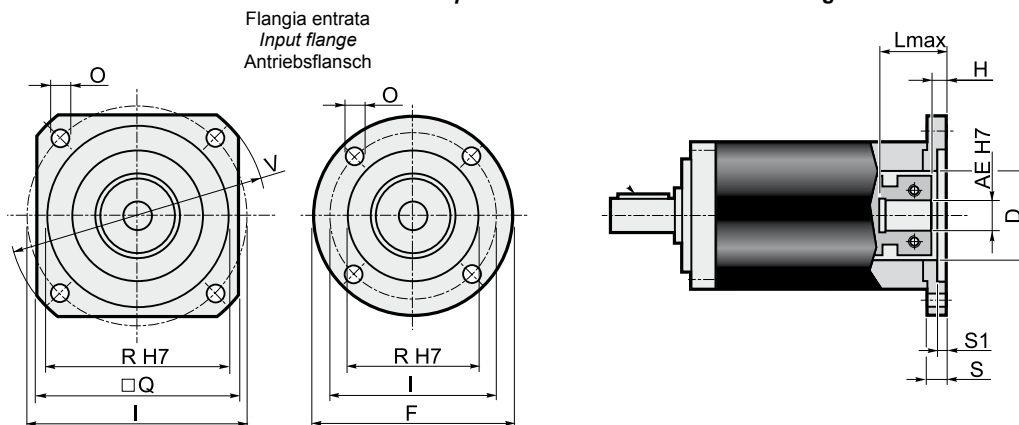

	Flange entrata / Input flange / Antriebsflansch									Albero entrata / Input shaft / Antriebswelle													
										AE													
	F	Q	V	I	R (H7)	O	S	S1	D	6	6.35	7	8	9	9.52	11							
									L _{max}	H	L _{max}	H	L _{max}	H	L _{max}	H	L _{max}	H	L _{max}	H	L _{max}	H	
P01*	60	=	=	43.82	22	4.5	10	3	22	30	7	30	7	30	7	30	7	30	7	30	7	30	7
P02*	=	60	80	66.67	38.1	5.5	10	3	32	30	7	30	7	30	7	30	7	30	7	30	7	30	7
P03*	=	60	80	63	40	5.5	10	3.5	32	30	7	30	7	30	7	30	7	30	7	30	7	30	7
P04	=	70	90	75	60	6.5	10.5	3.5	32	30.5	7.5	30.5	7.5	30.5	7.5	30.5	7.5	30.5	7.5	30.5	7.5	30.5	7.5
P05	105	=	=	85	70	6.5	10.5	3.5	32	30.5	7.5	30.5	7.5	30.5	7.5	30.5	7.5	30.5	7.5	30.5	7.5	30.5	7.5
P06	=	80	110	98.42	73.02	6	11	3.5	35	31	8	31	8	31	8	31	8	31	8	31	8	31	8
P07	=	95	120	100	80	6.5	11.5	4	32	31.5	8.5	31.5	8.5	31.5	8.5	31.5	8.5	31.5	8.5	31.5	8.5	31.5	8.5
P08	=	98	130	115	95	9	11.5	4	32	31.5	8.5	31.5	8.5	31.5	8.5	31.5	8.5	31.5	8.5	31.5	8.5	31.5	8.5
P09	=	116	160	130	110	9	12	4.5	32	32	9	32	9	32	9	32	9	32	9	32	9	32	9
P10*	60	=	=	39	26	4.5	10	3	26	30	7	30	7	30	7	30	7	30	7	30	7	30	7
P11*	60	=	=	42	32	4.5	10	3	32	30	7	30	7	30	7	30	7	30	7	30	7	30	7
P12*	65	=	=	46	32	4.5	10	3.5	32	30	7	30	7	30	7	30	7	30	7	30	7	30	7
P13*	80	=	=	65	50	5.5	10	3.5	32	30	7	30	7	30	7	30	7	30	7	30	7	30	7
P14*	60	=	=	39	20	4.5	10	2.5	20	30	7	30	7	30	7	30	7	30	7	30	7	30	7
P15	=	75	100	90	60	5.8	12	3.5	32	32	9	32	9	32	9	32	9	32	9	32	9	32	9
P16*	60	=	=	45	30	3.5	14	7	30	34	11	34	11	34	11	34	11	34	11	34	11	34	11
P17	=	60	82	70	50	4.5	16.5	8	32	36.5	13.5	36.5	13.5	36.5	13.5	36.5	13.5	36.5	13.5	36.5	13.5	36.5	13.5
P18	=	60	80	60	50	M4	10.5	3.5	32	30.5	7.5	30.5	7.5	30.5	7.5	30.5	7.5	30.5	7.5	30.5	7.5	30.5	7.5
P19*	60	=	=	36	25	4.5	10	3	25	30	7	30	7	30	7	30	7	30	7	30	7	30	7
P20	=	60	82	70	50	5.5	10.5	3.5	32	30.5	7.5	30.5	7.5	30.5	7.5	30.5	7.5	30.5	7.5	30.5	7.5	30.5	7.5
P21*	60	=	=	46	30	4.5	10	3	30	30	7	30	7	30	7	30	7	30	7	30	7	30	7
P22	=	60	80	70.71	36	4.5	10	2	32	30	7	30	7	30	7	30	7	30	7	30	7	30	7
P23	=	62	85	70	50	5.5	15.5	3.5	32	35.5	12.5	35.5	12.5	35.5	12.5	35.5	12.5	35.5	12.5	35.5	12.5	35.5	12.5
P24	=	75	100	90	70	5.8	12	3.5	32	32	9	32	9	32	9	32	9	32	9	32	9	32	9
P25	=	70	95	85	55	5.8	12	3.5	32	32	9	32	9	32	9	32	9	32	9	32	9	32	9
P26*	=	60	80	65.5	34	5.5	10	3.5	33	30	7	30	7	30	7	30	7	30	7	30	7	30	7
P27	=	80	110	95	50	6.5	12	3.5	32	32	9	32	9	32	9	32	9	32	9	32	9	32	9
P28	=	60	80	66.67	38.1	M4	9	2.5	32	29	6	29	6	29	6	29	6	29	6	29	6	29	6
P29	60	=	=	45	30	M3	11	4	32	31	8	31	8	31	8	31	8	31	8	31	8	31	8
P30	=	70	95	85	60	5.8	12	3.5	32	32	9	32	9	32	9	32	9	32	9	32	9	32	9
P31	=	62	85	70	50	M4	11	3.5	32	31	8	31	8	31	8	31	8	31	8	31	8	31	8
P32	=	60	80	65	40	M5	10	3.5	32	30	7	30	7	30	7	30	7	30	7	30	7	30	7
P33	=	85	115	99	60	5.5	11	3.5	35	31	8	31	8	31	8	31	8	31	8	31	8	31	8
P34	=	65	87	73.54	40	M4	10	3.5	32	30	7	30	7	30	7	30	7	30	7	30	7	30	7
P35	=	60	80	70.71	36	M4	14	2	32	34	11	34	11	34	11	34	11	34	11	34	11	34	11
P36	=	85	115	98.42	73.02	6	15	3.5	35	35	12	35	12	35	12	35	12	35	12	35	12	35	12
P38	60	=	=	48	30	M3	11	7	32	31	8	31	8	31	8	31	8	31	8	31	8	31	8
P41*	68	=	=	50	30	5.5	10	10	30	30	7	30	7	30	7	30	7	30	7	30	7	30	7

* Per assemblare il motore è necessario smontare la flangia dal riduttore (vedere schema di montaggio 2 a pag. 45).

* Before the mounting of the motor it is necessary to remove the flange from the gearbox (see structural arrangement 2 at the top of the page 45).

* Vor dem Einbauen des Motors soll die Getriebeflange abmontiert werden (siehe Bauanleitung 2 auf Seite 45).

EP 75																		Stadi Steps Stufenzahl	
Stadi Steps Stufenzahl	1					2												1	2
	i	3	4	5	7	10	9	12	15	16	20	25	28	35	40	50	70		
T _{2N}	22	28	32	28	20	26	32	36	36	36	36	36	36	36	36	30	22	n _{1nom}	4000
T _{2A}	40	45	50	45	40	50	60	60	60	60	60	60	60	60	60	50	45	n _{1max}	5000
T _{2S}	80	90	100	90	80	100	120	120	120	120	120	120	120	120	120	100	90	LpA	< 70
J	Vedi pag. 31 / See page 31 / Siehe auf Seite 31																	Lh	20000
R _t	3.5					3.0					3.5					3.0		F _{R2}	1800
R _d	0.96					0.93												F _{A2}	1400
Kg	1.4					2.0												α _{max}	8' 10'

2.9 Dimensioni

2.9 Dimensions

2.9 Abmessungen

Dimensioni generali e uscite / General and output dimensions / General-und Abtriebsabmessungen

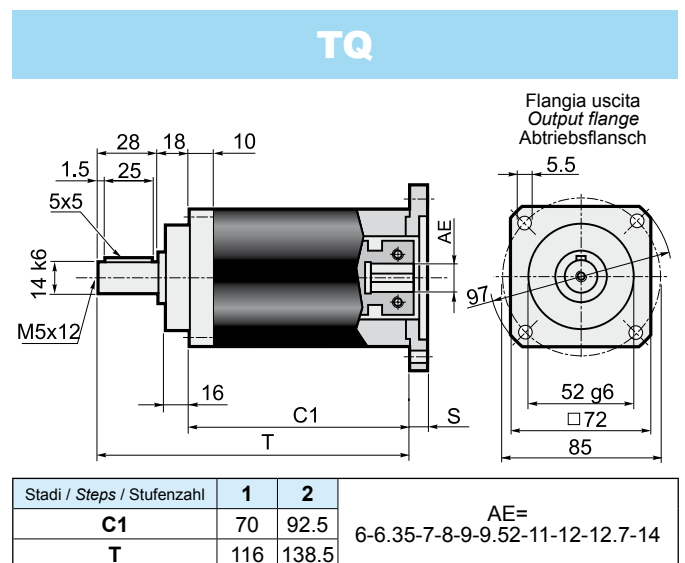
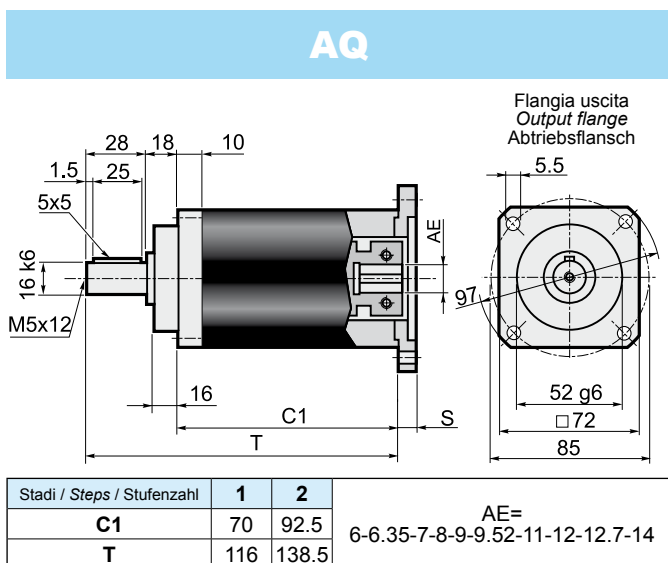
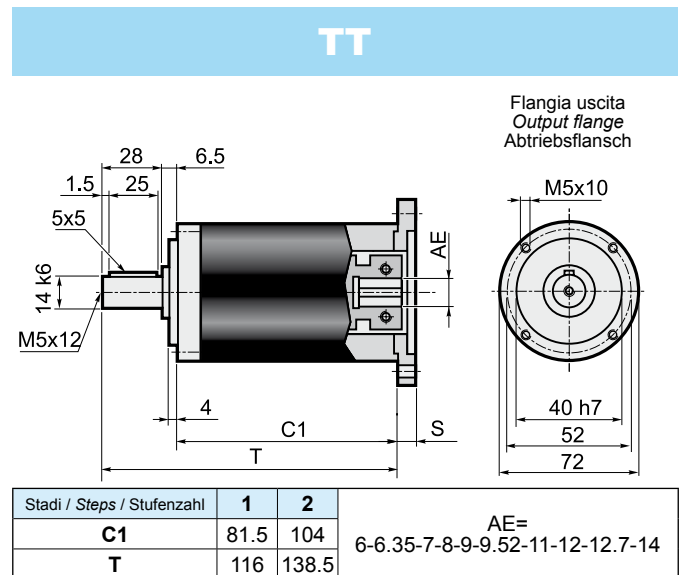
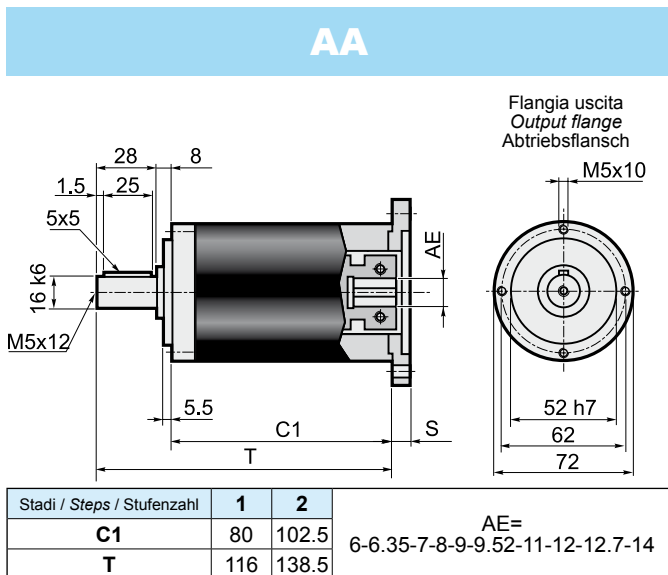

Dimensioni entrate / Input dimensions / Antriebsabmessungen

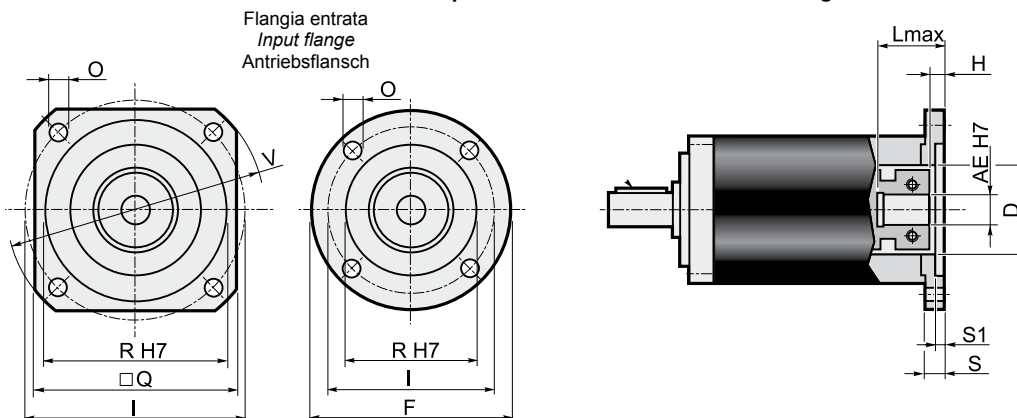

Flange entrata / Input flange / Antriebsflansch										Albero entrata / Input shaft / Antriebswelle																			
										AE																			
										6		6.35		7		8		9		9.52		11		12		12.7		14	
F	Q	V	I	R (H7)	O	S	S1	D	L _{max}	H	L _{max}	H	L _{max}	H	L _{max}	H	L _{max}	H	L _{max}	H	L _{max}	H	L _{max}	H	L _{max}	H			
P01*	60	=	=	43.82	22	4.5	10	3	22	35	4.5	35	4.5	35	4.5	26	6.5	26	6.5	35	6.5	26	6.5	35	6.5	35	6.5	35	6.5
P02*	=	60	80	66.67	38.1	5.5	10	3	32	35	4.5	35	4.5	35	4.5	26	6.5	26	6.5	35	6.5	26	6.5	35	6.5	35	6.5	35	6.5
P03*	=	60	80	63	40	5.5	10	3.5	32	35	4.5	35	4.5	35	4.5	26	6.5	26	6.5	35	6.5	26	6.5	35	6.5	35	6.5	35	6.5
P04	=	70	90	75	60	6.5	10.5	3.5	32	35.5	5	35.5	5	35.5	5	26.5	7	26.5	7	35.5	7	26.5	7	35.5	7	35.5	7	35.5	7
P05	105	=	=	85	70	6.5	10.5	3.5	32	35.5	5	35.5	5	35.5	5	26.5	7	26.5	7	35.5	7	26.5	7	35.5	7	35.5	7	35.5	7
P06	=	80	110	98.42	73.02	6	11	3.5	35	36	5.5	36	5.5	36	5.5	27	7.5	27	7.5	36	7.5	27	7.5	36	7.5	36	7.5	36	7.5
P07	=	95	120	100	80	6.5	11.5	4	32	36.5	6	36.5	6	36.5	6	27.5	8	27.5	8	36.5	8	27.5	8	36.5	8	36.5	8	36.5	8
P08	=	98	130	115	95	9	11.5	4	32	36.5	6	36.5	6	36.5	6	27.5	8	27.5	8	36.5	8	27.5	8	36.5	8	36.5	8	36.5	8
P09	=	116	160	130	110	9	12	4.5	32	37	6.5	37	6.5	37	6.5	28	8.5	28	8.5	37	8.5	28	8.5	37	8.5	37	8.5	37	8.5
P10*	60	=	=	39	26	4.5	10	3	26	35	4.5	35	4.5	35	4.5	26	6.5	26	6.5	35	6.5	26	6.5	35	6.5	35	6.5	35	6.5
P11*	60	=	=	42	32	4.5	10	3	32	35	4.5	35	4.5	35	4.5	26	6.5	26	6.5	35	6.5	26	6.5	35	6.5	35	6.5	35	6.5
P12*	65	=	=	46	32	4.5	10	3.5	32	35	4.5	35	4.5	35	4.5	26	6.5	26	6.5	35	6.5	26	6.5	35	6.5	35	6.5	35	6.5
P13*	80	=	=	65	50	5.5	10	3.5	32	35	4.5	35	4.5	35	4.5	26	6.5	26	6.5	35	6.5	26	6.5	35	6.5	35	6.5	35	6.5
P14*	60	=	=	39	20	4.5	10	2.5	20	35	4.5	35	4.5	35	4.5	26	6.5	26	6.5	35	6.5	26	6.5	35	6.5	35	6.5	35	6.5
P15	=	75	100	90	60	5.8	12	3.5	32	37	6.5	37	6.5	37	6.5	28	8.5	28	8.5	37	8.5	28	8.5	37	8.5	37	8.5	37	8.5
P16*	60	=	=	45	30	3.5	14	7	30	39	8.5	39	8.5	39	8.5	30	10.5	30	10.5	39	10.5	30	10.5	39	10.5	39	10.5	39	10.5
P17	=	60	82	70	50	4.5	16.5	8	32	41.5	11	41.5	11	41.5	11	32.5	13	32.5	13	41.5	13	32.5	13	41.5	13	41.5	13	41.5	13
P18	=	60	80	60	50	M4	10.5	3.5	32	35.5	5	35.5	5	35.5	5	26.5	7	26.5	7	35.5	7	26.5	7	35.5	7	35.5	7	35.5	7
P19*	60	=	=	36	25	4.5	10	3	25	35	4.5	35	4.5	35	4.5	26	6.5	26	6.5	35	6.5	26	6.5	35	6.5	35	6.5	35	6.5
P20	=	60	82	70	50	5.5	10.5	3.5	32	35.5	5	35.5	5	35.5	5	26.5	7	26.5	7	35.5	7	26.5	7	35.5	7	35.5	7	35.5	7
P21*	60	=	=	46	30	4.5	10	3	30	35	4.5	35	4.5	35	4.5	26	6.5	26	6.5	35	6.5	26	6.5	35	6.5	35	6.5	35	6.5
P22	=	60	80	70.71	36	4.5	10	2	32	35	4.5	35	4.5	35	4.5	26	6.5	26	6.5	35	6.5	26	6.5	35	6.5	35	6.5	35	6.5
P23	=	62	85	70	50	5.5	15.5	3.5	32	40.5	10	40.5	10	40.5	10	31.5	12	31.5	12	40.5	12	31.5	12	40.5	12	40.5	12	40.5	12
P24	=	75	100	90	70	5.8	12	3.5	32	37	6.5	37	6.5	37	6.5	28	8.5	28	8.5	37	8.5	28	8.5	37	8.5	37	8.5	37	8.5
P25	=	70	95	85	55	5.8	12	3.5	32	37	6.5	37	6.5	37	6.5	28	8.5	28	8.5	37	8.5	28	8.5	37	8.5	37	8.5	37	8.5
P26*	=	60	80	65.5	34	5.5	10	3.5	33	35	4.5	35	4.5	35	4.5	26	6.5	26	6.5	35	6.5	26	6.5	35	6.5	35	6.5	35	6.5
P27	=	80	110	95	50	6.5	12	3.5	32	37	6.5	37	6.5	37	6.5	28	8.5	28	8.5	37	8.5	28	8.5	37	8.5	37	8.5	37	8.5
P28	=	60	80	66.67	38.1	M4	9	2.5	32	34	3.5	34	3.5	34	3.5	25	5.5	25	5.5	34	5.5	25	5.5	34	5.5	34	5.5	34	5.5
P29	60	=	=	45	30	M3	11	4	32	36	5.5	36	5.5	36	5.5	27	7.5	27	7.5	36	7.5	27	7.5	36	7.5	36	7.5	36	7.5
P30	=	70	95	85	60	5.8	12	3.5	32	37	6.5	37	6.5	37	6.5	28	8.5	28	8.5	37	8.5	28	8.5	37	8.5	37	8.5	37	8.5
P31	=	62	85	70	50	M4	11	3.5	32	36	5.5	36	5.5	36	5.5	27	7.5	27	7.5	36	7.5	27	7.5	36	7.5	36	7.5	36	7.5
P32	=	60	80	65	40	M5	10	3.5	32	35	4.5	35	4.5	35	4.5	26	6.5	26	6.5	35	6.5	26	6.5	35	6.5	35	6.5	35	6.5
P33	=	85	115	99	60	5.5	11	3.5	32	36	5.5	36	5.5	36	5.5	27	7.5	27	7.5	36	7.5	27	7.5	36	7.5	36	7.5	36	7.5
P34	=	65	87	73.54	40	M4	10	3.5	32	35	4.5	35	4.5	35	4.5	26	6.5	26	6.5	35	6.5	26	6.5	35	6.5	35	6.5	35	6.5
P35	=	60	80	70.71	36	M4	14	2	32	39	8.5	39	8.5	39	8.5	30	10.5	30	10.5	39	10.5	30	10.5	39	10.5	39	10.5	39	10.5
P36	=	85	115	98.42	73.02	6	15	3.5	35	40	9.5	40	9.5	40	9.5	35	11.5	31	11.5	40	11.5	35	11.5	40	11.5	40	11.5	40	11.5
P38	60	=	=	48	30	M3	11	7	32	36	5.5	36	5.5	36	5.5	27	7.5	27	7.5	36	7.5	27	7.5	36	7.5	36	7.5	36	7.5
P41*	68	=	=	50	30	5.5	10	10	30	35	4.5	35	4.5	35	4.5	26	6.5	26	6.5	35	6.5	26	6.5	35	6.5	35	6.5	35	6.5

* Per assemblare il motore è necessario smontare la flangia dal riduttore (vedere schema di montaggio 2 a pag. 45).

* Before the mounting of the motor it is necessary to remove the flange from the gearbox (see structural arrangement 2 at the top of the page 45).

* Vor dem Einbauen des Motors soll die Getriebeflang abmontiert werden (siehe Bauanleitung 2 auf Seite 45).

EP 90																		Stadi Steps Stufenzahl		
Stadi Steps Stufenzahl	1					2												1	2	
	i	3	4	5	7	10	9	12	15	16	20	25	28	35	40	50	70			100
T _{2N}	50	55	60	55	50	65	70	75	75	75	75	75	75	75	75	65	55	n _{1nom}	4000	
T _{2A}	80	90	100	90	80	100	110	120	120	120	120	120	120	120	120	100	90	n _{1max}	5000	
T _{2S}	160	180	200	180	160	200	220	240	240	240	240	240	240	240	240	200	180	LpA	< 70	
J	Vedi pag. 32 / See page 32 / Siehe auf Seite 32																	Lh	20000	
R _t	9.0					7.5					9.0					7.5			F _{R2}	2600
R _d	0.96					0.93												F _{A2}	2000	
Kg	2.8					3.7												α _{max}	8' 10'	

2.9 Dimensioni

2.9 Dimensions

2.9 Abmessungen

Dimensioni generali e uscite / General and output dimensions / General-und Abtriebsabmessungen

AA

Flangia uscita
Output flange
Abtriebsflansch

Stadi / Steps / Stufenzahl	1	2	AE= 9-9.52-11-12-12.7-14-15.87-16-19
C1	98	127	
T	144	173	

TT

Flangia uscita
Output flange
Abtriebsflansch

Stadi / Steps / Stufenzahl	1	2	AE= 9-9.52-11-12-12.7-14-15.87-16-19
C1	101	130	
T	144	173	

AQ

Flangia uscita
Output flange
Abtriebsflansch

Stadi / Steps / Stufenzahl	1	2	AE= 9-9.52-11-12-12.7-14-15.87-16-19
C1	88	117	
T	144	173	

TQ

Flangia uscita
Output flange
Abtriebsflansch

Stadi / Steps / Stufenzahl	1	2	AE= 9-9.52-11-12-12.7-14-15.87-16-19
C1	88	117	
T	144	173	

Dimensioni entrate / Input dimensions / Antriebsabmessungen

Flangia entrata
Input flange
Antriebsflansch

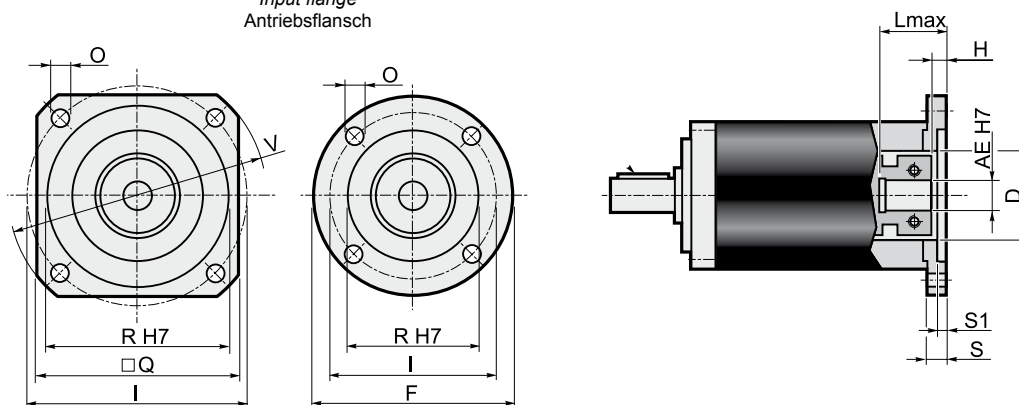

Flange entrata / Input flange / Antriebsflansch										Albero entrata / Input shaft / Antriebswelle																	
										AE																	
										9		9.525		11		12		12.7		14		15.87		16		19	
F	Q	V	I	R (H7)	O	S	S1	D	L max	H	L max	H	L max	H	L max	H	L max	H	L max	H	L max	H	L max	H			
P01*	80	=	=	66.67	38.1	5.5	12	3	38.1	44	6.5	44	9	29	9	44	9	44	9	44	9	44	9	44	9	44	9
P02	=	106.5	140	125.72	55.52	7	11	3	45	43	5.5	43	8	28	8	43	8	43	8	43	8	43	8	43	8	43	8
P03*	=	80	90	75	60	5.5	12	3.5	45	44	6.5	44	9	29	9	44	9	44	9	44	9	44	9	44	9	44	9
P04*	105	=	=	85	70	6.5	12	3.5	45	44	6.5	44	9	29	9	44	9	44	9	44	9	44	9	44	9	44	9
P05	=	82.5	110	98.425	73.02	6.5	12	3	45	44	6.5	44	9	29	9	44	9	44	9	44	9	44	9	44	9	44	9
P06	=	90	120	100	80	6.5	13	4	45	45	7.5	45	10	30	10	45	10	45	10	45	10	45	10	45	10	45	10
P07	=	100	135	115	95	8.5	13	4.5	45	45	7.5	45	10	30	10	45	10	45	10	45	10	45	10	45	10	45	10
P08	=	116	160	130	110	9	13	4.5	45	45	7.5	45	10	30	10	45	10	45	10	45	10	45	10	45	10	45	10
P09*	80	=	=	39	26	4.5	12	4	26	44	6.5	44	9	29	9	44	9	44	9	44	9	44	9	44	9	44	9
P10*	80	=	=	65	50	5.5	12	3.5	45	44	6.5	44	9	29	9	44	9	44	9	44	9	44	9	44	9	44	9
P11	=	150	182	166	115	9	32	11	50x14	64	26.5	64	29	49	29	64	29	64	29	64	29	64	29	64	29	64	29
P12*	=	80	105	90	70	6.5	12	3.5	32	44	6.5	44	9	29	9	44	9	44	9	44	9	44	9	44	9	44	9
P14*	105	=	=	90	70	6	19	9	32	51	13.5	51	16	36	16	51	16	51	16	51	16	51	16	51	16	51	16
P15*	80	=	=	70	50	4.5	17	8	45	49	11.5	49	14	34	14	49	14	49	14	49	14	49	14	49	14	49	14
P16	=	142	190	165	130	11	13	4.5	45	45	7.5	45	10	30	10	45	10	45	10	45	10	45	10	45	10	45	10
P17*	80	=	=	63	40	5.5	12	3.5	40	44	6.5	44	9	29	9	44	9	44	9	44	9	44	9	44	9	44	9
P18	=	130	170	145	110	M8	31	7	32	63	25.5	63	28	48	28	63	28	63	28	63	28	63	28	63	28	63	28
P19*	=	80	105	90	60	6.5	12	3.5	32	44	6.5	44	9	29	9	44	9	44	9	44	9	44	9	44	9	44	9
P20*	=	80	105	85	55	5.5	12	3.5	36	44	6.5	44	9	29	9	44	9	44	9	44	9	44	9	44	9	44	9
P21	=	80	110	95	50	M6	12	3.5	45	44	6.5	44	9	29	9	44	9	44	9	44	9	44	9	44	9	44	9
P22	80	=	=	70	50	M4	12	4	45	44	6.5	44	9	29	9	44	9	44	9	44	9	44	9	44	9	44	9
P23	=	80	90	75	60	M5	12	3.5	45	44	6.5	44	9	29	9	44	9	44	9	44	9	44	9	44	9	44	9
P24	80	=	=	46	30	M4	12	4	30	44	6.5	44	9	29	9	44	9	44	9	44	9	44	9	44	9	44	9
P26	80	=	=	65	40	M5	12	3.5	40	44	6.5	44	9	29	9	44	9	44	9	44	9	44	9	44	9	44	9
P27	=	80	105	82.02	36.8	M6	14	10	36.8	46	8.5	46	11	31	11	46	11	46	11	46	11	46	11	46	11	46	11
P28	=	90	120	100	80	6.5	28	4	45	60	22.5	60	25	45	25	60	25	60	25	60	25	60	25	60	25	60	25
P29*	80	=	=	66.67	50	5.5	12	3	45	44	6.5	44	9	29	9	44	9	44	9	44	9	44	9	44	9	44	9
P30	=	115	155	130	80	9	13	4	45	45	7.5	45	10	30	10	45	10	45	10	45	10	45	10	45	10	45	10
P31*	=	80	105	56	44	M6	14	10	36.8	46	8.5	46	11	31	11	46	11	46	11	46	11	46	11	46	11	46	11
P32	=	80	105	90	70	M6	12	3.5	32	44	6.5	44	9	29	9	44	9	44	9	44	9	44	9	44	9	44	9
P33	=	130	165	145	110	9	13	4.5	45	45	7.5	45	10	30	10	45	10	45	10	45	10	45	10	45	10	45	10
P34	=	90	120	100	80	M6	19	5	45	51	13.5	51	16	36	16	51	16	51	16	51	16	51	16	51	16	51	16
P36	=	100	135	115	95	M8	25	4.5	45	57	19.5	57	22	42	22	57	22	57	22	57	22	57	22	57	22	57	22
P37	=	85	115	98.99	60	M6	12	3.5	32	44	6.5	44	9	29	9	44	9	44	9	44	9	44	9	44	9	44	9
P38	80	=	=	70	50	M5	12	4	45	44	6.5	44	9	29	9	44	9	44	9	44	9	44	9	44	9	44	9
P39	=	90	120	100	80	6.5	13	4.5	45	45	7.5	45	10	30	10	45	10	45	10	45	10	45	10	45	10	45	10
P40	=	80	90	75	60	M6	12	3.5	45	44	6.5	44	9	29	9	44	9	44	9	44	9	44	9	44	9	44	9

* Per assemblare il motore è necessario smontare la flangia dal riduttore (vedere schema di montaggio 2 a pag. 45).

* Before the mounting of the motor it is necessary to remove the flange from the gearbox (see structural arrangement 2 at the top of the page 45).

* Vor dem Einbauen des Motors soll die Getriebeflang abmontiert werden (siehe Bauanleitung 2 auf Seite 45).

EP 120																		Stadi Steps Stufenzahl	
Stadi Steps Stufenzahl	1					2												1	2
i	3	4	5	7	10	9	12	15	16	20	25	28	35	40	50	70	100	1	2
T _{2N}	120	150	180	150	100	150	180	220	220	220	220	220	220	220	220	170	110	n _{1nom}	3000
T _{2A}	190	240	290	220	180	240	290	350	350	350	350	350	350	350	350	270	200	n _{1max}	4000
T _{2S}	400	500	600	460	380	500	600	700	700	700	700	700	700	700	700	540	400	LpA	< 70
J	Vedi pag. 32 / See page 32 / Siehe auf Seite 32																	Lh	20000
R _t	32				28	32	30						28					F _{R2}	4500
R _d	0.96					0.93												F _{A2}	4000
Kg	7.5					8.0												α _{max}	8' 10'

2.9 Dimensioni

2.9 Dimensions

2.9 Abmessungen

Dimensioni generali e uscite / General and output dimensions / General-und Abtriebsabmessungen

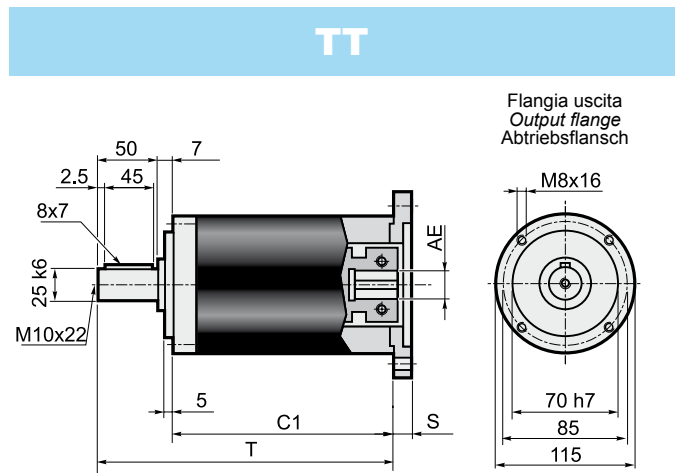
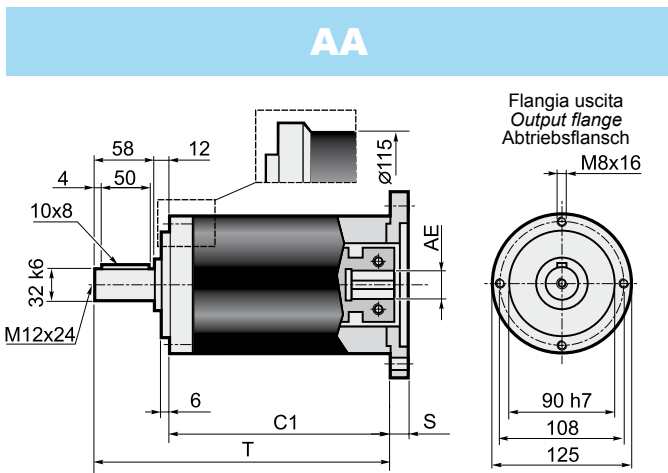

Stadi / Steps / Stufenzahl	1	2	AE= 12.7-14-15.87-16-19
C1	115.8	148.4	
T	185.8	218.4	
Stadi / Steps / Stufenzahl	1	2	AE= 22-24-25-28
C1	134.8	167.4	
T	185.8	218.4	

Stadi / Steps / Stufenzahl	1	2	AE= 12.7-14-15.87-16-19
C1	120.8	153.4	
T	177.8	210.4	
Stadi / Steps / Stufenzahl	1	2	AE= 22-24-25-28
C1	139.8	172.4	
T	196.8	229.4	

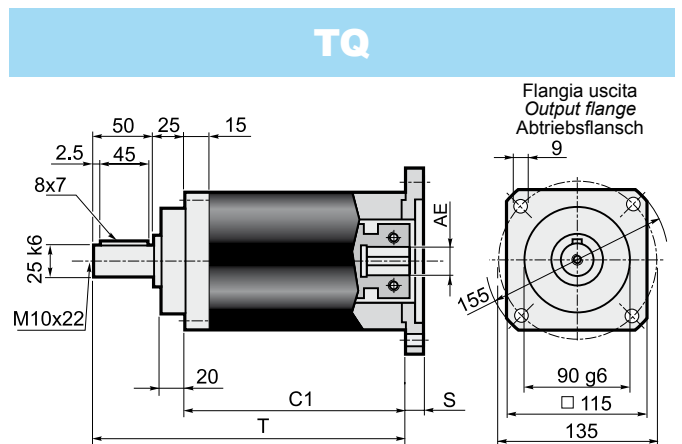
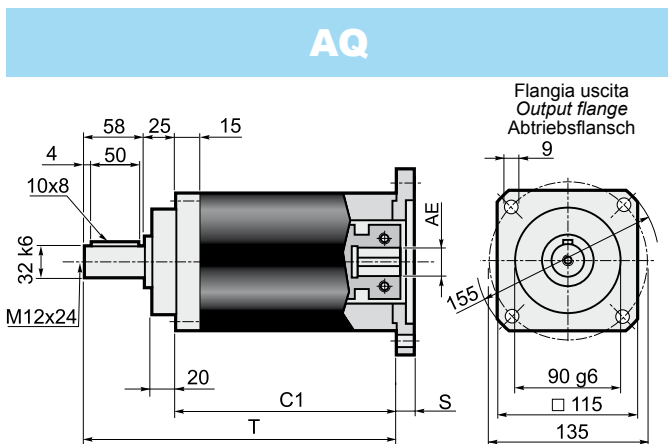

Stadi / Steps / Stufenzahl	1	2	AE= 12.7-14-15.87-16-19
C1	102.8	135.4	
T	185.8	218.4	
Stadi / Steps / Stufenzahl	1	2	AE= 22-24-25-28
C1	121.8	154.4	
T	204.8	237.4	

Stadi / Steps / Stufenzahl	1	2	AE= 12.7-14-15.87-16-19
C1	102.8	135.4	
T	177.8	210.4	
Stadi / Steps / Stufenzahl	1	2	AE= 22-24-25-28
C1	121.8	154.4	
T	196.8	229.4	

Dimensioni entrate / Input dimensions / Antriebsabmessungen

Flangia entrata
Input flange
Antriebsflansch

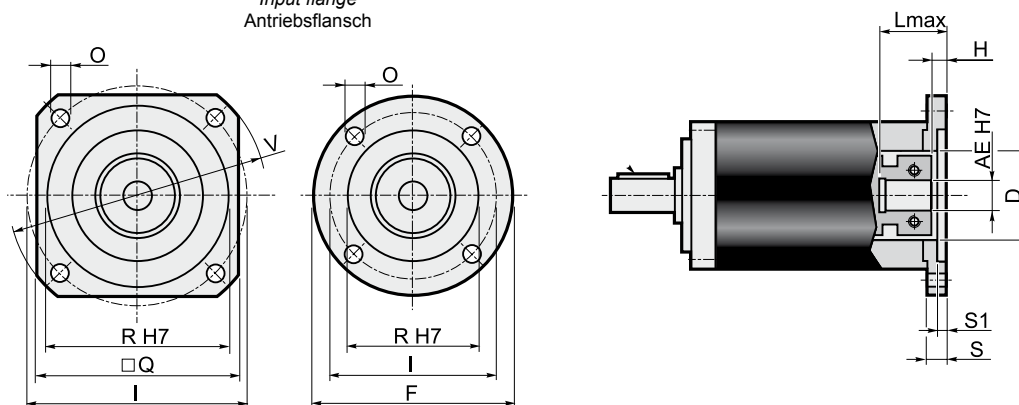

Flange entrata / Input flange / Antriebsflansch										Albero entrata / Input shaft / Antriebswelle																	
										AE																	
										12.7		14		15.87		16		19		22		24		25		28	
F	Q	V	I	R (H7)	O	S	S1	D	L _{max}	H	L _{max}	H	L _{max}	H	L _{max}	H	L _{max}	H	L _{max}	H	L _{max}	H	L _{max}	H			
P01*	=	115	140	125.72	55.52	6.5	13	3	55.52	43	6	35	6	43	6	43	6	43	6	62	6	62	6	62	6	62	6
P02*	115	=	=	75	60	5.5	13	3.5	60	43	6	35	6	43	6	43	6	43	6	62	6	62	6	62	6	62	6
P03*	115	=	=	85	70	6.5	13	3.5	60	43	6	35	6	43	6	43	6	43	6	62	6	62	6	62	6	62	6
P04*	115	=	=	98.42	73.02	6.5	13	3	60	43	6	35	6	43	6	43	6	43	6	62	6	62	6	62	6	62	6
P05*	120	=	=	100	80	6.5	13	4	60	43	6	35	6	43	6	43	6	43	6	62	6	62	6	62	6	62	6
P06*	=	115	140	115	95	9	13	4.5	60	43	6	35	6	43	6	43	6	43	6	62	6	62	6	62	6	62	6
P07	=	115	160	130	110	8.5	13	4.5	60	43	6	35	6	43	6	43	6	43	6	62	6	62	6	62	6	62	6
P08	=	142	190	165	130	11	13	4.5	60	43	6	35	6	43	6	43	6	43	6	62	6	62	6	62	6	62	6
P09	=	192	250	215	180	13	14	4.5	60	44	7	36	7	44	7	44	7	44	7	63	7	63	7	63	7	63	7
P10*	115	=	=	65	50	6.5	13	3.5	50	43	6	35	6	43	6	43	6	43	6	62	6	62	6	62	6	62	6
P11	=	130	170	145	110	M 8	31	7	60	61	24	53	24	61	24	61	24	61	24	80	24	80	24	80	24	80	24
P12	=	130	170	145	110	M 8	17	7	60	47	10	39	10	47	10	47	10	47	10	66	10	66	10	66	10	66	10
P13	=	115	160	130	110	M 8	13	4.5	60	43	6	35	6	43	6	43	6	43	6	62	6	62	6	62	6	62	6
P14*	115	=	=	70	50	6.5	13	3.5	50	43	6	35	6	43	6	43	6	43	6	62	6	62	6	62	6	62	6
P15	115	=	=	90	70	M5	11	3.5	60	41	4	33	4	41	4	41	4	41	4	60	4	60	4	60	4	60	4
P17*	115	=	=	90	70	6.5	13	3.5	60	43	6	35	6	43	6	43	6	43	6	62	6	62	6	62	6	62	6
P18	=	115	155	130	95	8.5	13	4.5	60	43	6	35	6	43	6	43	6	43	6	62	6	62	6	62	6	62	6
P19*	115	=	=	95	50	6.5	13	3.5	50	43	6	35	6	43	6	43	6	43	6	62	6	62	6	62	6	62	6
P20	115	=	=	99	60	M6	13	4	60	43	6	35	6	43	6	43	6	43	6	62	6	62	6	62	6	62	6
P21*	130	=	=	106	82.5	12.5	26.3	15	60	56.5	19.5	48.5	19.5	56.5	19.5	56.5	19.5	56.5	19.5	75.5	19.5	75.5	19.5	75.5	19.5	75.5	19.5
P22	=	144	190	165	110	11	15	4.5	60	45	8	37	8	45	8	45	8	45	8	64	8	64	8	64	8	64	8
P23*	115	=	=	63	40	5.5	11	3.5	40	41	4	33	4	41	4	41	4	41	4	60	4	60	4	60	4	60	4
P24	120	=	=	100	80	M6	18	7	60	48	11	40	11	48	11	48	11	48	11	67	11	67	11	67	11	67	11
P25	=	115	155	115	95	M8	27	4.5	60	57	20	49	20	57	20	57	20	57	20	76	20	76	20	76	20	76	20
P26	=	115	155	131.95	55.52	M8	27	4.5	60	57	20	49	20	57	20	57	20	57	20	76	20	76	20	76	20	76	20

* Per assemblare il motore è necessario smontare la flangia dal riduttore (vedere schema di montaggio 2 a pag. 45).

* Before the mounting of the motor it is necessary to remove the flange from the gearbox (see structural arrangement 2 at the top of the page 45).

* Vor dem Einbauen des Motors soll die Getriebeflange abmontiert werden (siehe Bauanleitung 2 auf Seite 45).

2.8 Dati tecnici

2.8 Technical data

2.8 Technische Daten

EP 155																		Stadi Steps Stufenzahl	
Stadi Steps Stufenzahl	1					2													
i	3	4	5	7	10	9	12	15	16	20	25	28	35	40	50	70	100	1	2
T _{2N}	240	320	380	300	220	320	400	500	500	500	500	500	500	500	500	350	250	n _{1nom}	3000
T _{2A}	420	540	600	480	400	480	600	750	750	750	750	750	750	750	750	560	460	n _{1max}	4000
T _{2S}	880	1140	1260	1000	850	1000	1250	1500	1500	1500	1500	1500	1500	1500	1500	1120	920	LpA	< 70
J	Vedi pag. 33 / See page 33 / Siehe auf Seite 33																	Lh	20000
R _t	60				50	60											50	F _{R2} (AA)	6500
																		F _{R2} (TT)	5300
R _d	0.96					0.93												F _{A2} (AA)	3250
																		F _{A2} (TT)	2650
Kg	10.9					15.7												α _{max}	8' 10'

2.9 Dimensioni

2.9 Dimensions

2.9 Abmessungen

Dimensioni generali e uscite / General and output dimensions / General-und Abtriebsabmessungen

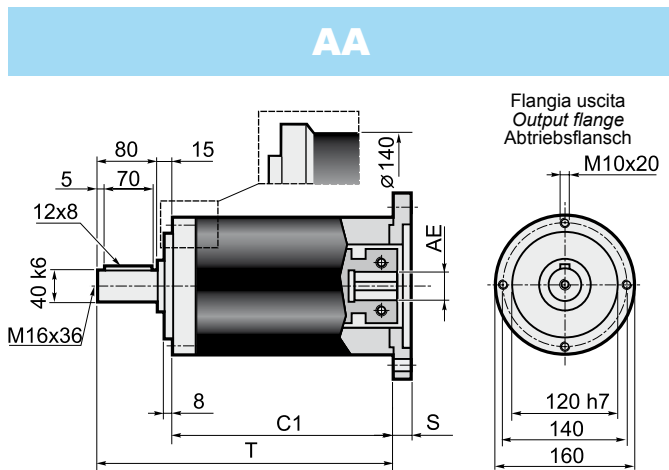

Stadi / Steps / Stufenzahl	1	2	AE= 15.87-16-19-22-24
C1	156	197.5	
T	251	292.5	
Stadi / Steps / Stufenzahl	1	2	AE= 28-32-35-38
C1	181	222.5	
T	276	317.5	

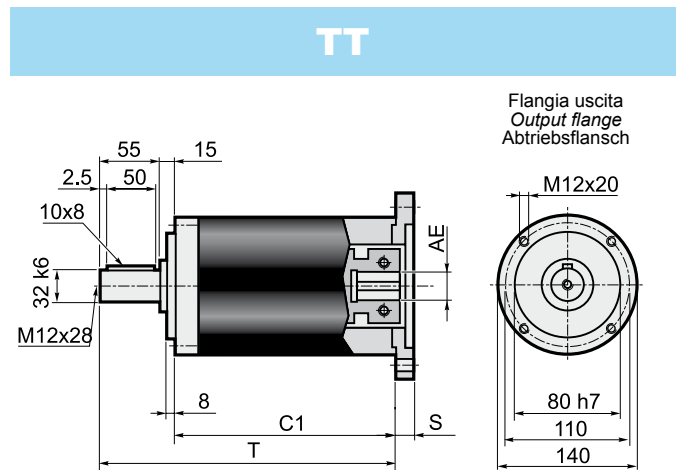

Stadi / Steps / Stufenzahl	1	2	AE= 15.87-16-19-22-24
C1	156	197.5	
T	226	267.5	
Stadi / Steps / Stufenzahl	1	2	AE= 28-32-35-38
C1	181	222.5	
T	251	292.5	

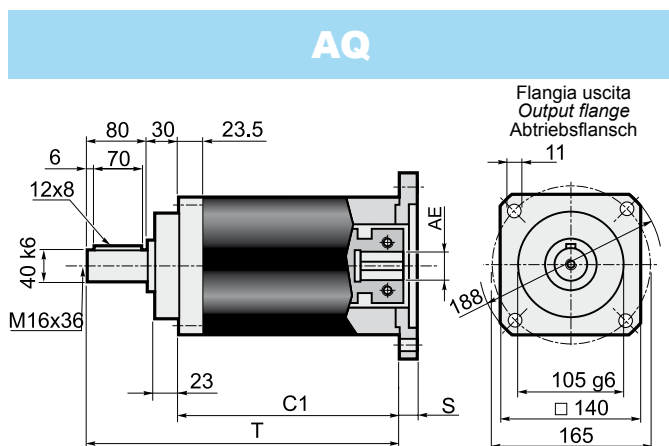

Stadi / Steps / Stufenzahl	1	2	AE= 15.87-16-19-22-24
C1	141	182.5	
T	251	292.5	
Stadi / Steps / Stufenzahl	1	2	AE= 28-32-35-38
C1	166	207.5	
T	276	317.5	

Dimensioni entrate / Input dimensions / Antriebsabmessungen

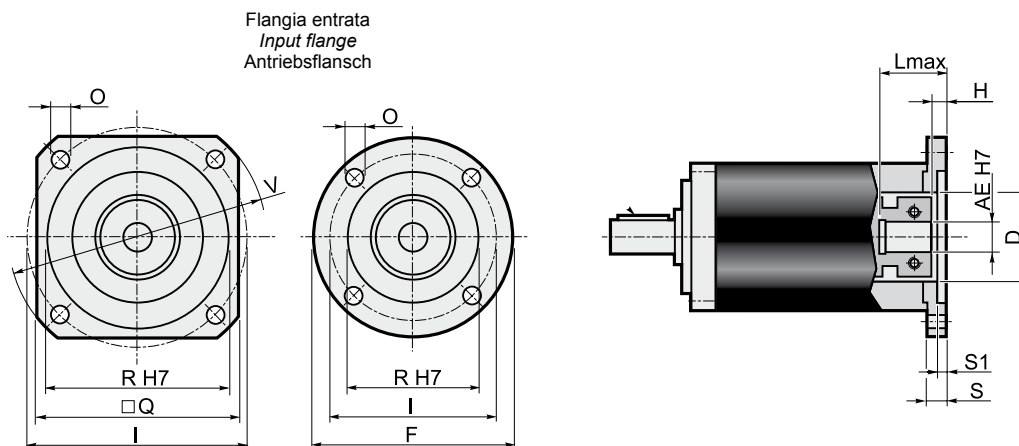

	Flange entrata / Input flange / Antriebsflansch									Albero entrata / Input shaft / Antriebswelle																	
										AE																	
										15.87		16		19		22		24		28		32		35		38	
F	Q	V	I	R (H7)	O	S	S1	D	L _{max}	H	L _{max}	H	L _{max}	H	L _{max}	H	L _{max}	H	L _{max}	H	L _{max}	H	L _{max}	H			
P01*	140	=	=	125.72	55.52	6.5	15	4	55.52	57.8	6.8	57.8	6.8	42.8	6.8	57.8	6.8	57.8	6.8	82.8	7.3	82.8	7.3	82.8	7.3	82.8	7.3
P02*	140	=	=	100	80	6.5	15	4	70	57.8	6.8	57.8	6.8	42.8	6.8	57.8	6.8	57.8	6.8	82.8	7.3	82.8	7.3	82.8	7.3	82.8	7.3
P03*	140	=	=	115	95	8.5	15	4.5	70	57.8	6.8	57.8	6.8	42.8	6.8	57.8	6.8	57.8	6.8	82.8	7.3	82.8	7.3	82.8	7.3	82.8	7.3
P04*	=	140	160	130	110	8.5	15	4.5	70	57.8	6.8	57.8	6.8	42.8	6.8	57.8	6.8	57.8	6.8	82.8	7.3	82.8	7.3	82.8	7.3	82.8	7.3
P05	=	142	190	165	130	11	15	4.5	70	57.8	6.8	57.8	6.8	42.8	6.8	57.8	6.8	57.8	6.8	82.8	7.3	82.8	7.3	82.8	7.3	82.8	7.3
P06	=	190	250	215	180	13	15	4.5	70	57.8	6.8	57.8	6.8	42.8	6.8	57.8	6.8	57.8	6.8	82.8	7.3	82.8	7.3	82.8	7.3	82.8	7.3
P07	=	250	300	265	230	13	15	4.5	70	57.8	6.8	57.8	6.8	42.8	6.8	57.8	6.8	57.8	6.8	82.8	7.3	82.8	7.3	82.8	7.3	82.8	7.3
P08	=	130	165	145	110	M 8	18	7	70	60.8	9.8	60.8	9.8	45.8	9.8	60.8	9.8	60.8	9.8	85.8	10.3	85.8	10.3	85.8	10.3	85.8	10.3
P09	=	180	230	200	114.3	13.5	22	11	70	64.8	13.8	64.8	13.8	49.8	13.8	64.8	13.8	64.8	13.8	89.8	14.3	89.8	14.3	89.8	14.3	89.8	14.3
P10	=	115	150	130	95	M 8	15	4.5	70	57.8	6.8	57.8	6.8	42.8	6.8	57.8	6.8	57.8	6.8	82.8	7.3	82.8	7.3	82.8	7.3	82.8	7.3
P11	=	180	230	198	155	13.5	22	7	120x11	64.8	13.8	64.8	13.8	49.8	13.8	64.8	13.8	64.8	13.8	89.8	14.3	89.8	14.3	89.8	14.3	89.8	14.3
P12	=	220	270	235	200	13.5	15	5	70	57.8	6.8	57.8	6.8	42.8	6.8	57.8	6.8	57.8	6.8	82.8	7.3	82.8	7.3	82.8	7.3	82.8	7.3
P13	=	190	250	215	130	13	15	4.5	70	57.8	6.8	57.8	6.8	42.8	6.8	57.8	6.8	57.8	6.8	82.8	7.3	82.8	7.3	82.8	7.3	82.8	7.3
P14	=	142	190	165	110	11	15	4.5	70	57.8	6.8	57.8	6.8	42.8	6.8	57.8	6.8	57.8	6.8	82.8	7.3	82.8	7.3	82.8	7.3	82.8	7.3
P15*	150	=	=	90	70	6.5	15	4	70	57.8	6.8	57.8	6.8	42.8	6.8	57.8	6.8	57.8	6.8	82.8	7.3	82.8	7.3	82.8	7.3	82.8	7.3
P16	=	146	200	177.8	114.3	10.5	15	3.5	70	57.8	6.8	57.8	6.8	42.8	6.8	57.8	6.8	57.8	6.8	82.8	7.3	82.8	7.3	82.8	7.3	82.8	7.3
P17	=	130	165	145	110	M 8	28	7	70	-	-	-	-	70.8	19.8	-	-	-	-	-	-	-	-	-	-	-	-
P18	140	=	=	100	80	M 6	22	6	70	64.8	13.8	64.8	13.8	49.8	13.8	64.8	13.8	64.8	13.8	89.8	14.3	89.8	14.3	89.8	14.3	89.8	14.3

* Per assemblare il motore è necessario smontare la flangia dal riduttore (vedere schema di montaggio 2 a pag. 45).

* Before the mounting of the motor it is necessary to remove the flange from the gearbox (see structural arrangement 2 at the top of the page 45).

* Vor dem Einbauen des Motors soll die Getriebeflangens abmontiert werden (siehe Bauanleitung 2 auf Seite 45).

1 Schema di montaggio / Assembly drawing / Bauanleitung 1

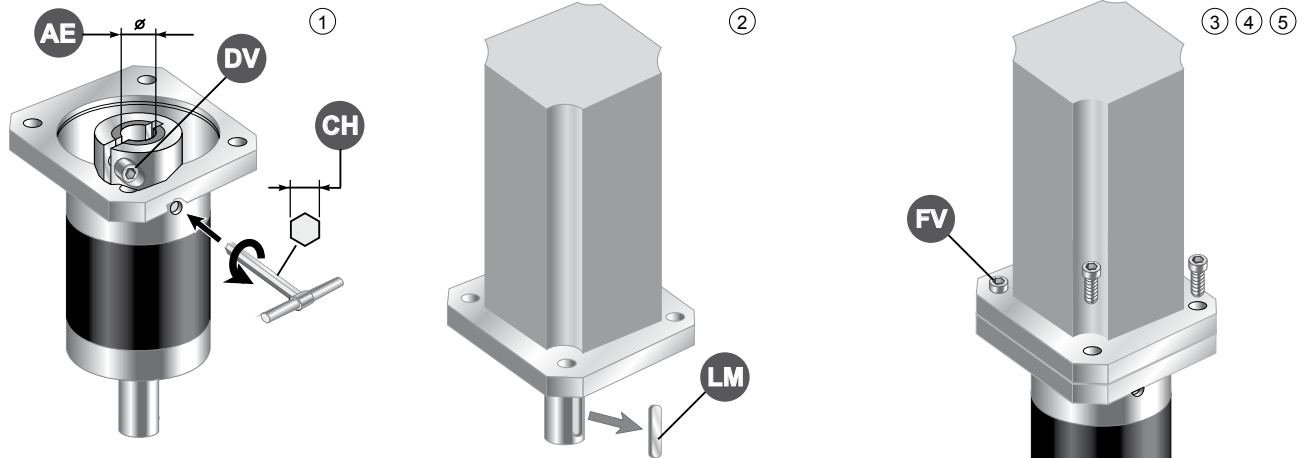

- 1 - Allentare la vite di serraggio del morsetto (DV)
- 2 - Estrarre la linguetta (LM) dall'albero motore
- 3 - Pulire le superfici di contatto delle flange motore e riduttore
- 4 - Calettare il motore sul riduttore evitando urti
- 5 - Stringere le viti di assemblaggio (FV) in modo alternato
- 6 - Assicurarsi che il morsetto venga serrato posizionandolo verso il motore e rispettando la fasatura dei tagli
- 7 - Serrare la vite (o le viti) del morsetto (DV) alla coppia (CS) indicata in tabella

- 1 - Unloose the fastening screw (or screws) of the clamp (DV)
- 2 - Remove the key (LM) from motor shaft
- 3 - Clean the contact surfaces of motor flange/gearbox flange
- 4 - Avoid impacts while fitting motor to gearbox
- 5 - Tighten the assembling screws (FV) alternately
- 6 - Fix the clamp towards the motor and tighten it in compliance with the cuts timing
- 7 - Tighten the clamp screw, or screws (DV) according to the torque (CS) reported in the table

- 1 - die Befestigungsschraube der Klammer (DV) lockern
- 2 - die Feder (LM) aus Motorwelle ziehen
- 3 - die Motorflansch / Getriebeflansch Kontaktfläche reinigen
- 4 - Motor und Getriebe ohne Stöße verkeilen
- 5 - die Befestigungsschrauben (FV) abwechselnd anziehen
- 6 - Die Klammer soll zum Motor angezogen. Dabei soll die Zuendeinstellung de Schnitte geachtet
- 7 - die Schraube (oder Schrauben) der Klammer (DV) zu dem in der Tabelle angegebenen Anzugsmoment anziehen

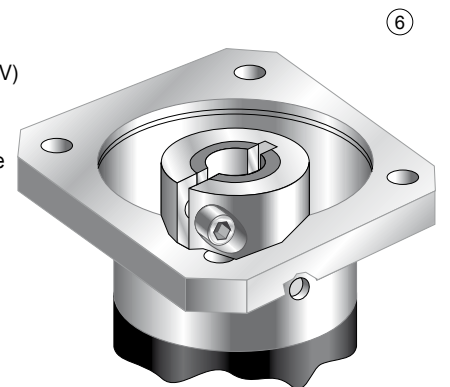

EP 55	AE	6	6.35	7	8	9	9.52	11				
	DV	M4 x 16										
	NV	1										
	CH	3										
	CS [Nm]	4.8										
EP 75	AE	6	6.35	7	8	9	9.52	11	12	12.7	14	
	DV	M4 x 16										
	NV	1										
	CH	3										
	CS [Nm]	4.8										
EP 90	AE	9	9.52	11	12	12.7	14	15.87	16	19		
	DV	M4 x 16						M5 x 20				
	NV	1						1				
	CH	3						4				
	CS [Nm]	4.8						9.4				
EP 120	AE	12.7	14	15.87	16	19	22	24	25	28		
	DV	M4 x 16		M5 x 20			M6 x 20					
	NV	1		1			2					
	CH	3		4			5					
	CS [Nm]	4.8		9.4			16.2					
EP 155	AE	15.87	16	19	22	24	28	32	35	38		
	DV	M6 x 20			M6 x 20			M6 x 20				
	NV	1			2			3				
	CH	5			5			5				
	CS [Nm]	16.2			16.2			16.2				

Tutte le viti hanno classe di resistenza 12.9
 All screws supplied according to strenght class 12.9
 Alle Schrauben nach Festigkeitsklasse 12.9 geliefert

AE= Albero entrata / Input shaft / Antriebswelle
 DV= Diametro vite / Screw diameter / Schraubendurchmesser

NV= Numero viti / Number of screw / Schraubenanzahl
 CS= Coppia di serraggio / Setting torque / Spannungsmoment

2

Schema di montaggio / Assembly drawing / Bauanleitung 2

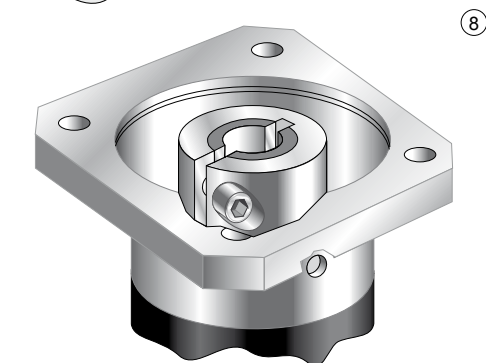
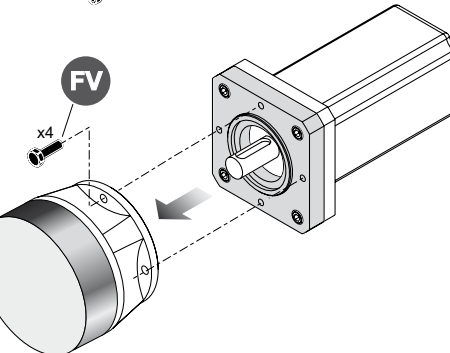
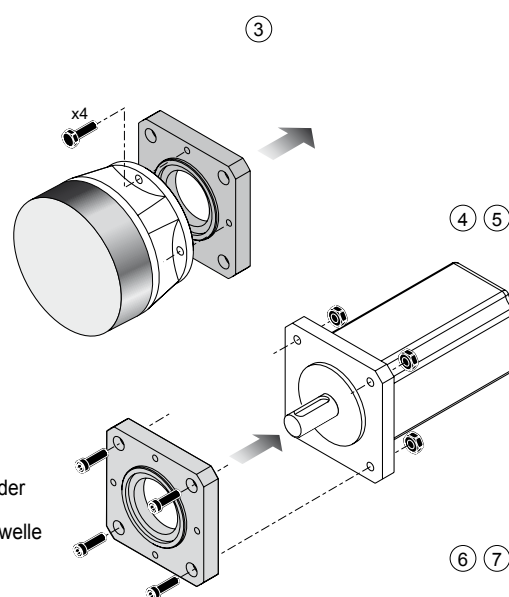
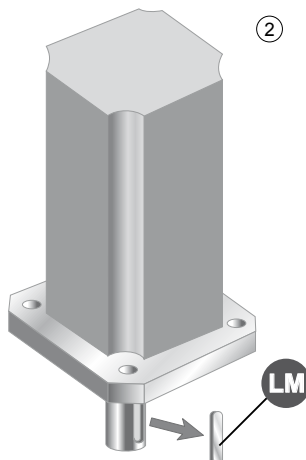
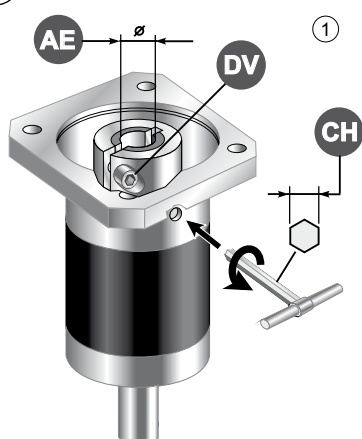

- 1 - Allentare la vite di serraggio del morsetto (DV)
- 2 - Estrarre la linguetta (LM) dall'albero motore
- 3 - Smontare la flangia dal riduttore
- 4 - Pulire le superfici di contatto delle flange motore e riduttore
- 5 - Fissare la flangia sul motore
- 6 - Calettare il motore sul riduttore evitando urti
- 7 - Stringere le viti di assemblaggio (FV) in modo alternato
- 8 - Assicurarsi che il morsetto venga serrato posizionandolo verso il motore e rispettando la fasatura dei tagli
- 9 - Serrare la vite (o le viti) del morsetto (DV) alla coppia (CS) indicata in tabella

- 1 - Unloose the fastening screw (or screws) of the clamp (DV)
- 2 - Remove the key (LM) from motor shaft
- 3 - Remove the flange from the gearbox
- 4 - Clean the contact surfaces of motor flange/gearbox flange
- 5 - Fix the flange on the motor
- 6 - Avoid impacts while fitting motor to gearbox
- 7 - Tighten the assembling screws (FV) alternatively
- 8 - Fix the clamp towards the motor and tighten it in compliance with the cuts timing
- 9 - Tighten the clamp screw, or screws (DV) according to the torque (CS) reported in the table

- 1 - die Befestigungsschraube der Klammer (DV) lockern
- 2 - die Feder (LM) aus Motorwelle ziehen
- 3 - die Flansch von Getriebe abmontieren
- 4 - die Motorflansch / Getriebe-flansch Kontaktfläche reinigen
- 5 - die Flansch an Motor befestigen
- 6 - Motor und Getriebe ohne Stöße verkeilen
- 7 - die Befestigungsschrauben (FV) abwechselnd anziehen
- 8 - Die Klammer soll zum Motor angezogen. Dabei soll die Zuendeinstellung de Schnitte geachtet
- 9 - die Schraube (oder Schrauben) der Klammer (DV) zu dem in der Tabelle angegebenen Anzugsmoment anziehen

EP 55	AE	6	6.35	7	8	9	9.52	11					
	DV	M4 x 16											
	NV	1											
	CH	3											
	CS [Nm]	4.8											
EP 75	AE	6	6.35	7	8	9	9.52	11	12	12.7	14		
	DV	M4 x 16											
	NV	1											
	CH	3											
	CS [Nm]	4.8											
EP 90	AE	9	9.52	11	12	12.7	14	15.87	16	19			
	DV	M4 x 16								M5 x 20			
	NV	1								1			
	CH	3								4			
	CS [Nm]	4.8								9.4			
EP 120	AE	12.7	14	15.87	16	19	22	24	25	28			
	DV	M4 x 16			M5 x 20				M6 x 20				
	NV	1			1				2				
	CH	3			4				5				
	CS [Nm]	4.8			9.4				16.2				
EP 155	AE	15.87	16	19	22	24	28	32	35	38			
	DV	M6 x 20			M6 x 20				M6 x 20				
	NV	1			2				3				
	CH	5			5				5				
	CS [Nm]	16.2			16.2				16.2				

Tutte le viti hanno classe di resistenza 12.9

All screws supplied according to strenght class 12.9

Alle Schrauben nach Festigkeitsklasse 12.9 geliefert

AE= Albero entrata / Input shaft / Antriebswelle

DV= Diametro vite / Screw diameter / Schraubendurchmesser

NV= Numero viti / Number of screw / Schraubenanzahl

CS= Coppia di serraggio / Setting torque / Spannungsmoment

3.1 Esempi di applicazioni

3.1 Examples of applications

3.1 Anwendungsbeispiele

Carrello scorrevole

Sliding carriage

Laufwagen

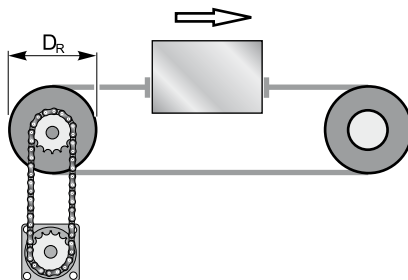

L'applicazione prevede la movimentazione lineare di una tavola tramite una catena (rapporto di riduzione della trasmissione: $i=1$)
 La massa del carrello è di $m=200$ kg e $D_R=0.1$ m.
 Il carrello deve essere accelerato in $t_a=0.2$ s ad una velocità massima $v_2=0.6$ m/s.
 Il rapporto di riduzione del riduttore è $i=20$.
 La forza resistente che si oppone allo spostamento è pari a $F=500$ N (data dal prodotto della forza per il coefficiente di attrito).

The application requires the linear motion of a table by means of a chain (reduction ratio of the transmission: $i=1$).
 The carriage mass is $m=200$ Kg and $D_R=0.1$ m.
 The carriage has to be accelerated in $t_a=0.2$ s to a maximum speed $v_2=0.6$ m/s.
 The reduction ratio of the gearbox is $i=20$
 The resisting force acting against the motion is $F=500$ N (product of the force by the coefficient of friction).

Die Applikation sieht die Linearbewegung einer Scheibe durch eine Kette vor. (Übersetzungsverhältnis: $i=1$)
 Die Masse der Wagen ist $m=200$ Kg und $D_R=0.1$ m. Der Wagen soll in $t_a=0.2$ s bis Höchstgeschwindigkeit $v_2=0.6$ m/s beschleunigt werden.
 Das Übersetzungsverhältnis des Getriebes ist $i=20$.
 Die Widerstandskraft, die gegen die Bewegung wirkt, ist $F=500$ N (Produkt von Kraft mal Reibungskoeffizient)

- Determinazione della coppia resistente T_{RES}

$$T_{RES} = F \cdot D_R / 2 = 500 \cdot 0.1 / 2 = 25 \text{ Nm}$$

- Calculation of resisting torque T_{RES}

$$T_{RES} = F \cdot D_R / 2 = 500 \cdot 0.1 / 2 = 25 \text{ Nm}$$

- Berechnung von Widerstandsdrehmoment

$$T_{RES} = F \cdot D_R / 2 = 500 \cdot 0.1 / 2 = 25 \text{ Nm}$$

- Determinazione della coppia resistente T_{IN} dovuta all'inerzia

$$T_{IN} = F_i \cdot D_R / 2 \text{ (Nm)}$$

- Calculation of resisting torque of inertia T_{IN}

$$T_{IN} = F_i \cdot D_R / 2 \text{ (Nm)}$$

- Berechnung von Trägheitsdrehmoment T_{IN}

$$T_{IN} = F_i \cdot D_R / 2 \text{ (Nm)}$$

Dove F_i è la forza di inerzia, la quale, nel caso di traslazione, vale:

$$F_i = m \cdot a \quad \text{(N)}$$

F_i is the inertial force which, in case of translation, is:

$$F_i = m \cdot a \quad \text{(N)}$$

F_i ist die Trägheit, die im Falle von Translation wie folgt ist :

$$F_i = m \cdot a \quad \text{(N)}$$

In questo caso, l'accelerazione risulta:

$$a = (v_2 - v_0) / t_a \quad \text{(m/s}^2\text{)}$$

con v_2 = velocità finale (m/s)
 v_0 = velocità iniziale (m/s)
 t_a = tempo di accelerazione (s)

quindi:

$$a = (0.6 - 0) / 0.2 = 3 \text{ m/s}^2$$

$$F_i = 200 \cdot 3 = 600 \text{ N}$$

$$T_{IN} = 600 \cdot 0.1 / 2 = 30 \text{ Nm}$$

In this case, acceleration is:

$$a = (v_2 - v_0) / t_a \quad \text{(m/s}^2\text{)}$$

v_2 = final speed
 v_0 = initial speed
 t_a = acceleration time (s)

Therefore:

$$a = (0.6 - 0) / 0.2 = 3 \text{ m/s}^2$$

$$F_i = 200 \cdot 3 = 600 \text{ N}$$

$$T_{IN} = 600 \cdot 0.1 / 2 = 30 \text{ Nm}$$

In diesem Fall ist die Beschleunigung wie folgt:

$$a = (v_2 - v_0) / t_a \quad \text{(m/s}^2\text{)}$$

Mit v_2 = Endgeschwindigkeit
 v_0 = Startgeschwindigkeit
 t_a = Beschleunigungszeit(s)

Folglich:

$$a = (0.6 - 0) / 0.2 = 3 \text{ m/s}^2$$

$$F_i = 200 \cdot 3 = 600 \text{ N}$$

$$T_{IN} = 600 \cdot 0.1 / 2 = 30 \text{ Nm}$$

Pertanto, la coppia da prendere in considerazione, per dimensionare correttamente l'applicazione, vale:

$$T_2 = T_{RES} + T_{IN} = 25 + 30 = 55 \text{ Nm}$$

As a result, for the purpose of a correct dimensioning of the application, the following torque has to be taken into consideration:

$$T_2 = T_{RES} + T_{IN} = 25 + 30 = 55 \text{ Nm}$$

Damit die Dimensionierung der Applikation korrekt ist, ist das folgendes Drehmoment zu betrachten:

$$T_2 = T_{RES} + T_{IN} = 25 + 30 = 55 \text{ Nm}$$

In funzione di questo risultato si dovrà individuare un adeguato motore (in prima approssimazione: $T_{MOT} = (T_2 / i) \cdot R_d$), tale cioè da garantire una coppia motrice sufficiente a vincere gli attriti e le inerzie presenti. Successivamente, in funzione delle caratteristiche del motore scelto e delle rimanenti specifiche dell'applicazione (ciclo di lavoro, numero di cicli all'ora ecc.) si procede selezionando opportunamente il riduttore (v. selezione del riduttore).

This value has to be taken into account when selecting the motor (approx. $T_{MOT} = (T_2 / i) \cdot R_d$). The motor torque should be high enough as to overcome friction and inertia forces. Subsequently, it is possible to proceed with the selection of the gearbox on the basis of motor specifications and features of application (operation cycle, no. cycles per hour, etc.) (see selection of the gearbox).

Von diesen Wert hängt die Wahl des Motors (annähernd : $T_{MOT} = (t_2 / i) \cdot R_d$) ab. Das Antriebsdrehmoment muss ausreichend hoch sein, um Reibungs- und Trägheitskräfte überwinden zu können. Schließlich wird das Getriebe abhängig von Applikation (Arbeitszyklus, Zyklen pro Stunde, u.s.w.) und Motoreigenschaften gewählt. (Siehe Wahl des Getriebes).

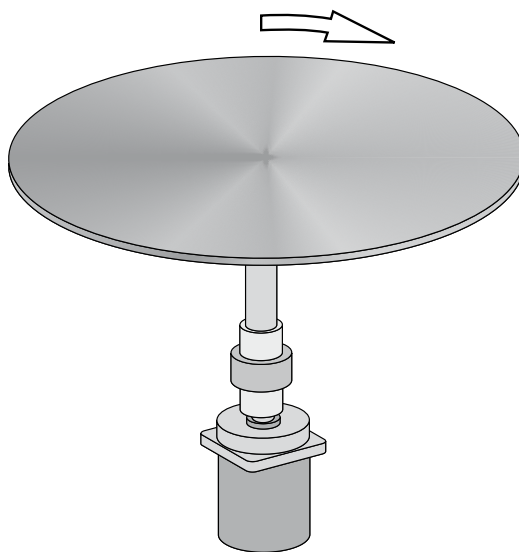
Tavola rotante
Revolving table
Drehscheibe

L'applicazione prevede la messa in rotazione di una tavola cilindrica di massa pari a $m=20\text{kg}$ e raggio $r=0.5\text{m}$.

Tale tavola deve essere accelerata da $n_0 = 0 \text{ min}^{-1}$ a $n_1 = 300 \text{ rpm}$ in $t_a = 0.3 \text{ s}$.

Il rapporto di riduzione del riduttore è $i=20$.

Si suppone che la coppia resistente per mantenere in rotazione uniforme la tavola sia trascurabile rispetto alla coppia legata all'inerzia dell'applicazione.

The application requires the rotation of a cylindrical table with mass $m=20 \text{ Kg}$ and radius $r=0.5\text{m}$.

The table has to be accelerated from $n_0=0 \text{ rpm}$ to $n_1=300 \text{ min}^{-1}$ in $t_a=0.3\text{s}$.

The reduction ratio of the gearbox is $i=20$.

The resisting torque, which enables uniform rotation of the table, is assumed to be negligible compared to the torque caused by the inertia of the application.

Die Applikation sieht die Drehung einer zylindrischen Scheibe vor, deren Masse $m=20\text{Kg}$ ist und deren Halbmesser $r=0.3$ ist.

Solche Scheibe soll von $n_0 = 0 \text{ U/Min}$ bis $n_1=300 \text{ min}^{-1}$ in $t_a=0.3\text{s}$ beschleunigt werden. Das Übersetzungsverhältnis des Getriebes ist $i=20$.

Es wird angenommen, dass das zur gleichmäßigen Drehung der Scheibe dienenden Widerstandsrehmoment unbeträchtlich im Vergleich zum Trägheitsmoment ist.

Quindi, in questo caso:

$$T_2 = T_{IN} = J \cdot a_a \quad (\text{Nm})$$

Dove $J \text{ (kgm}^2\text{)}$ è il momento d'inerzia di massa della tavola rotante, ed $a_a \text{ (rad/s}^2\text{)}$ è la accelerazione angolare.

$$J = (m \cdot r^2) / 2 = (20 \cdot 0.5^2) / 2 = 2.5 \text{ kgm}^2$$

$$a_a = \frac{\omega_1 - \omega_0}{t_a} \quad (\text{rad/s}^2)$$

$$\omega_1 = (2 \cdot \pi \cdot n_1) / 60 = (2 \cdot \pi \cdot 300) / 60 = 31.4 \text{ rad/s}$$

Quindi:

$$a_a = \frac{31.4 - 0}{0.3} = 104.6 \quad (\text{rad/s}^2)$$

Infine:

$$T_2 = T_{IN} = 2.5 \cdot 104.6 = 261 \text{ Nm}$$

In funzione di questo risultato si dovrà individuare un adeguato motore (in prima approssimazione: $T_{MOT} = (T_2 / i) \cdot R_d$), tale cioè da garantire una coppia motrice sufficiente a vincere gli attriti e le inerzie presenti. Successivamente, in funzione delle caratteristiche del motore scelto e delle rimanenti specifiche dell'applicazione (ciclo di lavoro, numero di cicli all'ora ecc.) si procede selezionando opportunamente il riduttore (v. selezione del riduttore).

Therefore, in this case:

$$T_2 = T_{IN} = J \cdot a_a \quad (\text{Nm})$$

$J \text{ (kgm}^2\text{)}$ is the moment of inertia of the mass of the revolving table and $a_a \text{ (rad/s}^2\text{)}$ is the angular acceleration.

$$J = (m \cdot r^2) / 2 = (20 \cdot 0.5^2) / 2 = 2.5 \text{ kgm}^2$$

$$a_a = \frac{\omega_1 - \omega_0}{t_a} \quad (\text{rad/s}^2)$$

$$\omega_1 = (2 \cdot \pi \cdot n_1) / 60 = (2 \cdot \pi \cdot 300) / 60 = 31.4 \text{ rad/s}$$

Therefore:

$$a_a = \frac{31.4 - 0}{0.3} = 104.6 \quad (\text{rad/s}^2)$$

In conclusion:

$$T_2 = T_{IN} = 2.5 \cdot 104.6 = 261 \text{ Nm}$$

This value has to be taken into account when selecting the motor (approx. $T_{MOT} = (T_2 / i) \cdot R_d$). The driving torque should be high enough as to overcome friction and inertia forces. Subsequently, proceed with the selection of the gearbox on the basis of motor specifications and features of application (operation cycle, no. cycles per hours, etc.) (see selection of the gearbox).

Folglich, in diesem Fall:

$$T_2 = T_{IN} = J \cdot a_a \quad (\text{Nm})$$

$J \text{ (kgm}^2\text{)}$ ist das Trägheitsmoment der Masse der Drehscheibe und $a_a \text{ (rad/s}^2\text{)}$ ist die Winkelbeschleunigung.

$$J = (m \cdot r^2) / 2 = (20 \cdot 0.5^2) / 2 = 2.5 \text{ kgm}^2$$

$$a_a = \frac{\omega_1 - \omega_0}{t_a} \quad (\text{rad/s}^2)$$

$$\omega_1 = (2 \cdot \pi \cdot n_1) / 60 = (2 \cdot \pi \cdot 300) / 60 = 31.4 \text{ rad/s}$$

Folglich:

$$a_a = \frac{31.4 - 0}{0.3} = 104.6 \quad (\text{rad/s}^2)$$

Schließlich:

$$T_2 = T_{IN} = 2.5 \cdot 104.6 = 261 \text{ Nm}$$

Von diesen Wert hängt die Wahl des Motors (annähernd: $T_{MOT} = (T_2 / i) \cdot R_d$) ab. Das Antriebsdrehmoment muss ausreichend hoch sein, um Reibungs- und Trägheitskräfte überwinden zu können. Schließlich wird das Getriebe abhängig von Applikation (Arbeitszyklus, Zyklen pro Stunde, u.s.w.) und Motoreigenschaften gewählt (siehe Wahl des Getriebes).

Calcolo dell'inerzia J / Calculation of inertia J / Berechnung der Trägheit J

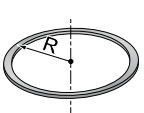
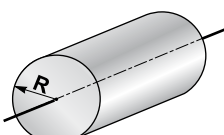
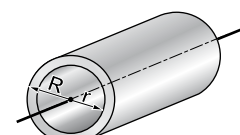
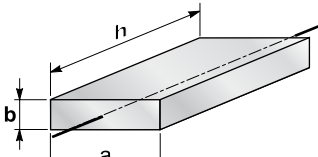
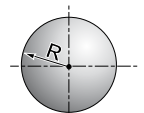
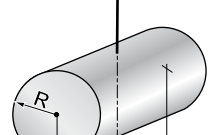
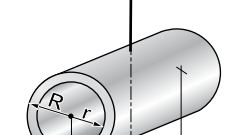
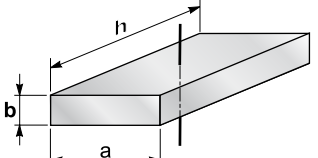
 $J = MR^2$	 $J = \frac{1}{2}MR^2$	 $J = \frac{M(R^2 + r^2)}{2}$	 $J = \frac{M(a^2 + b^2)}{12}$
 $J = \frac{2}{5}MR^2$	 $J = \frac{M}{4} \left(\frac{h^2}{3} + R^2 \right)$	 $J = \frac{M}{4} \left(\frac{h^2}{3} + R^2 + r^2 \right)$	 $J = \frac{M(h^2 + a^2)}{12}$

M	[Kg]	Massa	Weight	Maße
a, b, h	[m]	Dimensioni	Dimensions	Abmessungen
J	[Kgm ²]	Inerzia	Inertia	Trägheitsmoment

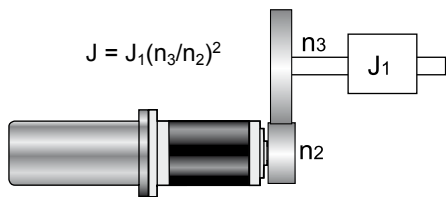

J = inerzia riferita all'albero uscita del riduttore con velocità n_2 [rad/s] derivante da una massa con inerzia J_1 e ruotante a velocità n_3 [rad/s].

J = inertia referred to the gearbox output shaft with speed n_2 [rad/s] resulting from a mass with inertia J_1 rotating at n_3 speed [rad/s].

J = Trägheit mit Bezug auf Getriebeabtriebswelle mit Drehzahl n_2 [rad/s], die von einer Masse mit Trägheit J_1 zu n_3 Drehzahl ableitet [rad/s].

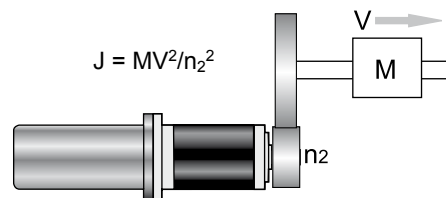

J = inerzia riferita all'albero uscita del riduttore con velocità n_2 [rad/s] derivante da una massa traslante M [Kg] a velocità V [m/s].

J = inertia referred to the gearbox output shaft with speed n_2 [rad/s] resulting from a translating mass M [Kg] at V speed [m/s].

J = Trägheit mit Bezug auf Getriebeabtriebswelle mit Drehzahl n_2 [rad/s], die von einer Translation-Masse M [Kg] zu V Drehzahl [m/s] ableitet.

Relazioni fondamentali fra coppia T [Nm], inerzia J [Kgm²] e accelerazione angolare a_a [rad/s²].

Fundamental relations between torque T [Nm], inertia J [Kgm²] and angular acceleration a_a [rad/s²].

Wesentliche Relationen zwischen Drehmoment T [Nm], Trägheit J [Kgm²] und Winkelbeschleunigung a_a [rad/s²].

$$T = J \cdot a_a$$

Relazioni fondamentali fra coppia e potenza in entrata (T1, P1) e in uscita (T2, P2), il rendimento Rd e il rapporto di riduzione i del riduttore.

Fundamental relations between input torque and power (T1, P1), output torque and power (T2, P2), efficiency Rd, gearbox reduction ratio i.

Wesentliche Relationen zwischen Antriebsdrehmoment und -leistung (T1, P1), Abtriebsdrehmoment und -leistung (T2, P2), Wirkungsgrad Rd, Untersetzungsverhältnis i des Getriebes.

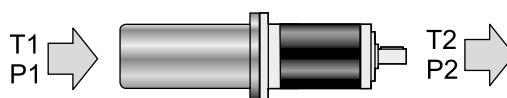

$$P2 = P1 \cdot Rd \quad T2 = T1 \cdot i \cdot Rd$$

**CONDIZIONI GENERALI DI GARANZIA**

La garanzia relativa a difetti di costruzione ha la durata di un anno dalla data di fatturazione delle merci. Tale garanzia comporta per la TRAMEC l'onere della sostituzione o riparazione delle parti difettose ma non ammette ulteriore addebito per eventuali danni diretti o indiretti di qualsiasi natura. La garanzia decade nel caso in cui non siano state osservate le disposizioni riportate nel manuale di uso e manutenzione e/o siano state eseguite riparazioni o apportate modifiche senza nostro consenso scritto.

La merce di ritorno sarà da noi accettata solo se spedita franco di ogni spesa.

GENERAL CODITIONAL OF WARRANTY

Warranty for manufacturing defects will expire one-year the invoicing date. TRAMEC will replace or repair defective parts but will not accept any further charges for direct or indirect damages of any kind. The warranty will become null and void if the instructions given in the use and maintenance manual are not complied with or if repairs or changes are carried out without our prior written authorization.

Returned goods will be accepted only if delivered free of any charge.

ALLGEMEINE GARANTIEBEDINGUNGEN

Die Garantie auf Herstellungsfehler dauert ein Jahr ab Rechnungsdatum der Ware. Aufgrund Garantie unterliegt der TRAMEC die Pflicht der Ersetzung oder Reparatur der defekten Teile, jedoch nicht die Übernahme weiterer Belastungen für direkte oder indirekte Schäden egal welcher Natur. Die Garantie verfällt bei Nichtbeachtung der in der betreffenden „Betriebs- und Instandhaltungsanleitung“ angeführten Anweisungen und/oder falls ohne unsere vorausgehende schriftliche Genehmigung Reparaturen oder Änderungen vorgenommen wurden.

Die an uns zurückgesendete Ware akzeptieren wir nur wenn gebührenfrei geliefert.

REVISIONI**REVISIONS****ÄNDERUNG**

06/2011	Modificata altezza EP75	06/2011	Change of EP 75 height	06/2011	Änderung der Höhe des Getriebes EP 75
01/2012	Ridotto gioco angolare EP	01/2012	Decreased angular backlash EP	01/2012	Reduziert Winkelspiel EP
03/2014	Modificate: dimensioni PAM REP 75 dimensioni C1 EP120	03/2014	Modify: dimensions PAM REP 75 dimensions C1 - EP120	03/2014	geändert: Größe PAM REP 75 Größe C1 - EP 120
04/2015	Aggiunti PAM REP Aggiunti PAM EP	04/2015	Add PAM REP Add date PAM EP	04/2015	Neue PAM REP Neue PAM EP

04/2015

Questo catalogo annulla e sostituisce ogni precedente edizione o revisione. Tutti i dati elencati sono indicativi e s'intendono senza impegno alcuno da parte nostra. Ci riserviamo il diritto di apportare modifiche senza preavviso.

This catalogue cancels and replaces any previous edition and revision. All listed data are approximate and it's understood that this entails no obligation on our part. We reserve the right to implement modifications without notice.

Mit der Ausgabe dieses Katalogs annullieren sich gleichzeitig alle bisherigen Katalogen. Sämtliche Daten sind Berechnete Werte die für den Verkäufer unverbindlich sind. Der Verkäufer behält sich das Recht vor, Änderungen, ohne eine vorhergehende Advisierung durchzuführen.